

A leader doesn't follow steps  
... he marks the way



## WHAT IS AN ABSORB?

A crash cushion (attenuator) with an enhanced quality cushion system due to its modular composition. This is a great quality because during vehicle's collision it doesn't rebound nor deviates. It's categorized as a suitable product according to regulation.

It could resist minor frontal impacts if it's filled with water.

Ideal as a crash cushion in streets, avenues and highways. As a suggestion, you could also use it in merges, accesses, junctions and everywhere else where you need higher road safety standards.

## FEATURES

- It provides excellent cover if it's placed in areas of risk, in medium-speed roads or as a warning in case of different events along the road like a hole, an open sewer, a landslide, etc.
- The **Low-cost Absorb 190 TCIA** incorporates the *Triple Container Impact Absorber (TCIA)*, our exclusive cushion modular technology with an engineered use of water as damping element.
- Each module is composed of an external container that in turn has a second and a third flexible container inside.
- Safety valve (Ø 3.93 in.): Once filled with water, its hermetic sealing avoids liquid losses by evaporation.
- Great protection for a low cost.
- Equipped with reflective strips all around its body for better visibility.
- It complies with the standard NOM-008-SCT2-2013.
- Colors: Blue or yellow.



Volumes, dimensions and other measures are nominal and may vary approximately 2 %.

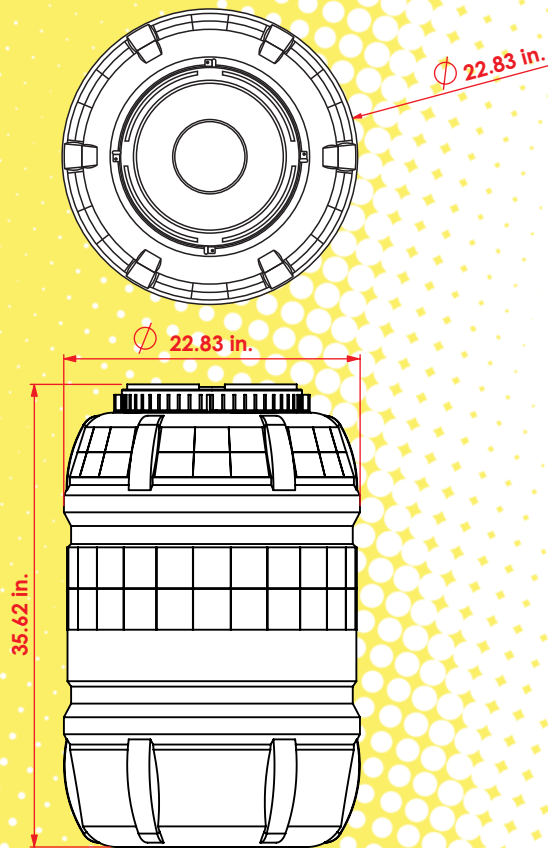

## TECHNICAL SPECIFICATIONS

* Made of:	Polyethylene.
* Volume capacity:	50.19 US gal
* Weight of the impact attenuator (empty):	264.90 oz.
* Impact attenuator measures:	ø 22.83 in. Height: 35.62 in.
* Body colors:	Yellow and blue.
* Reflective (optional):	Engineer Grade

