

## DIRECTIONAL ARROW BOARD LIGHT

Code: FBI-142



### FEATURES

- Device with electronic lighting.
- Perfect with two way arrow shape and round borders to avoid damages.
- Ideal to guide transit, with 3 functions:
  - Right Arrow.
  - Left Arrow.
  - Center Bar
- Excellent to set in emergency vehicles such as fire trucks and tow trucks.
- Flashing or steady mode.
- Great visibility in any climate condition.
- Powered by vehicle's battery, protecting life span through an specialized converter.
- Structured with 18 gauge sheet and steel skeleton.

#### LIGHTING SYSTEM

- 10 modules in amber or red color
- 12V CD power.
- Consumption of 0.5 Amperes to 1 Amperes/hour.
- 3 Functions.
- 656 ft visibility.
- Inbuilt control circuit.
- 140.000 mcd per cluster.

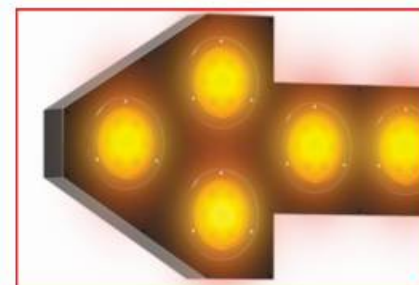

# DIRECTIONAL ARROW BOARD LIGHT

Code: FBI-142

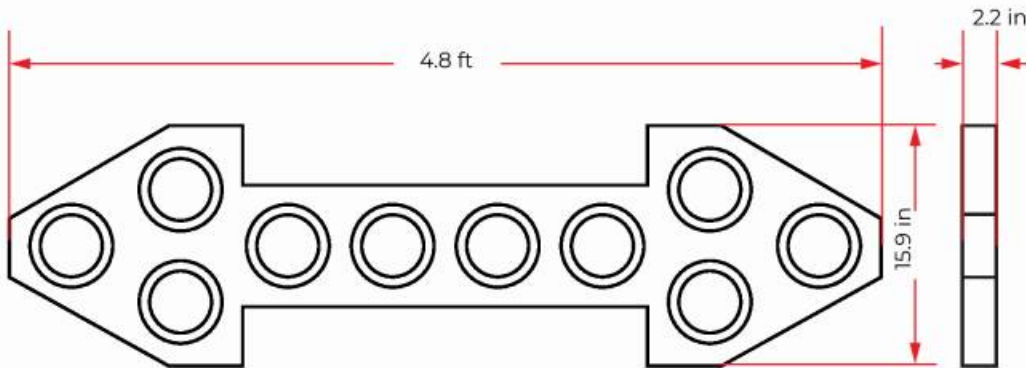

## MEASUREMENTS

Dimensions and other measures are nominal and may vary by + / - 2 %.

- |                    |  |
|--------------------|--|
| <b>Arrow Type</b>  | <ul style="list-style-type: none"> <li>• Two way arrow</li> </ul>  |
| <b>Made of</b>     | <ul style="list-style-type: none"> <li>• 18-gauge sheet in black color</li> </ul>                                      |
| <b>LED Modules</b> | <ul style="list-style-type: none"> <li>• 10 modules of 9 LEDs each</li> </ul>  |
| <b>LED Color</b>   | <ul style="list-style-type: none"> <li>• Red or amber</li> </ul>   |
| <b>Dimensions</b>  | <ul style="list-style-type: none"> <li>• Length: 4.8 ft</li> <li>• Width: 2.2 in</li> <li>• Height: 15.9 in</li> </ul> |

