

ARROW BOARD TRAILER

Code: RE-FLE

FEATURES

- Our trailer has the best signage system to prevent accidents.
- Luminous flashing device made of 16-gauge galvanized sheet box with anti-corrosion and black acrylic enamel coating.
- Lighting system is based on LED clusters (red or amber color) with intelligent control that is suitable to display different flashing sequences and speeds.
- 4" x 2" RHS metal body guarantees functionality in detours, work zones, land slides or repairs.
- Support with 14" tires and reinforced axles for easy management.
- It has accessories to ensure an optimal functioning, such as center jack to facilitate balance in sloping areas; navigation, direction and warning lights; and also wiring harness for lights.
- Solar power supply system by rechargeable photo voltaic panel of 60W-12V-40AH.

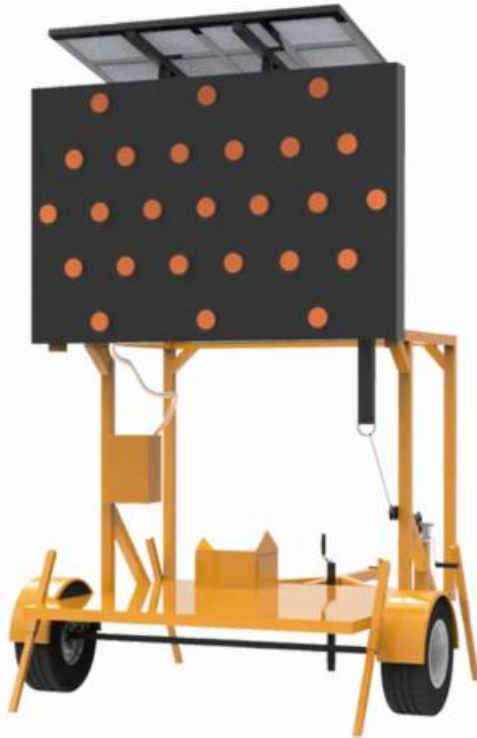

Flashing Types

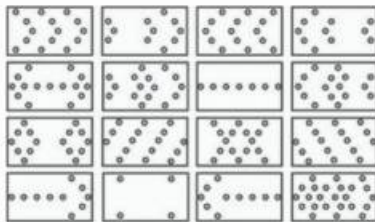

Arrow Panel

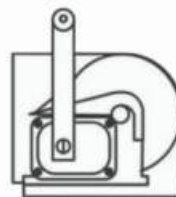
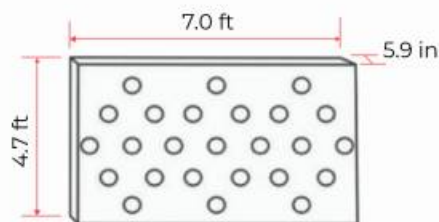

Winch

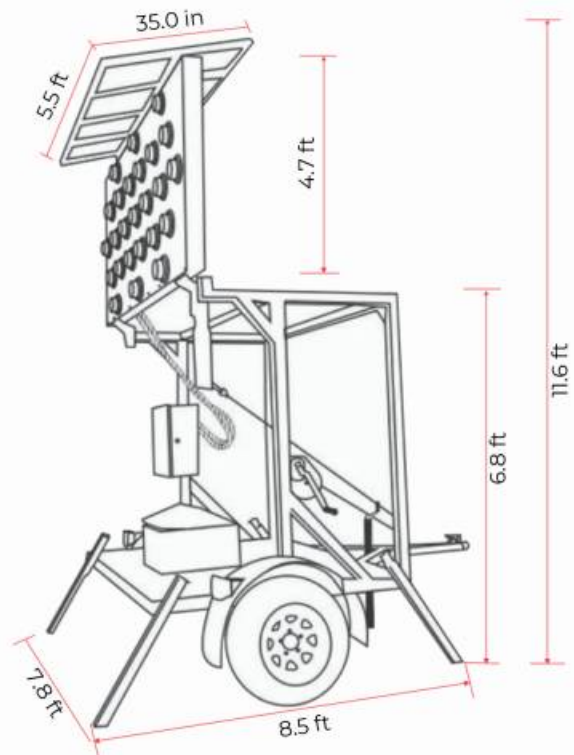

ARROW BOARD TRAILER

Code: RE-FLE

TECHNICAL SPECIFICATIONS

TRAILER	
Made of	<ul style="list-style-type: none"> 2.5" RHS, 1.5 galvanized RHS; 1 1/4" x 1/8" bracket; 16-gauge, 4" x 8" galvanized sheet.
Color	<ul style="list-style-type: none"> Yellow.
Measurements	<ul style="list-style-type: none"> Dragging/Towing: 7.8 x 8.5. Height: 11.6 ft.
Suspension	<ul style="list-style-type: none"> Leaf Spring System.
Support	<ul style="list-style-type: none"> 1,500 lbs axle.
Winch	<ul style="list-style-type: none"> 1,800 lbs.
BOARD	
Made of	<ul style="list-style-type: none"> 4"X2" RHS, 18 gauge black sheet.
Around Weight	<ul style="list-style-type: none"> 198.4 lbs
Power Supply	<ul style="list-style-type: none"> 12 volts.
Lights Qty	<ul style="list-style-type: none"> 25 LED clusters.
Light Life Span	<ul style="list-style-type: none"> 10 years.