

## LUMINOUS ARROW BOARDS

Code: FLE-15 / 18 or 25



### FEATURES

- Luminous Arrow Boards for road and work signage in detours, landslides, school zones, events, public or private construction zones, and others.
- Different options to satisfy your signage needs.
- Lighting options in red and amber color.
- Lights are controlled independently.
- Offering up to 16 flashing sequences and 3 speeds.
- Can be fixed or assembled.
- Flashing or sequential light.
- 4 power supply options: electric, solar, by generator or hybrid.
- ANTI-SALT AND ANTI-CORROSION PROTECTION TO WORK IN TROPICAL ENVIRONMENTS.

### LIGHTING

- Simple and electric power supply system to charge from direct current to 110V or 220V.
- Electronic lighting by converter to supply to 12V or 24V external battery .
- Solar supply system with photovoltaic panel of 50W of silicon, long life battery.
- 12V-28AH rechargeable battery guarantees 10-24 continuous functioning hours with full battery.
- SPECIAL power supply system.
- Hybrid power supply: 110-220V Electric power supply + 127V-3000W Generator + 240W-12V+ Solar.
- 1500W-12V Battery bank to guarantee its functioning for 24 continuous hours the 365 days of the year.
- Electronic power supply by 3KVA Generator with manual pull start. 3.9 gal tank capacity.
- Guaranteeing a minimum of 10 hours without fuel refilling. 02 available outlets, 01 thermal protection (20 Amp and 30 Amp) with (1/4) twist lock plug.

# LUMINOUS ARROW BOARDS

Code: FLE-15 / 18 o 25

Weight: 67.240 lbs

Weight: 81.571 lbs

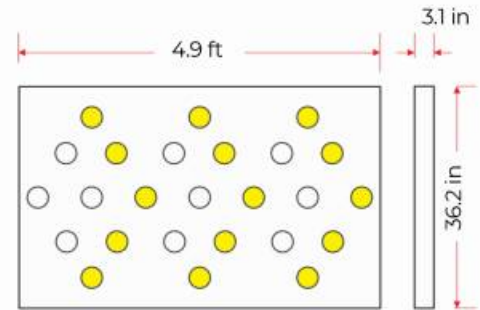
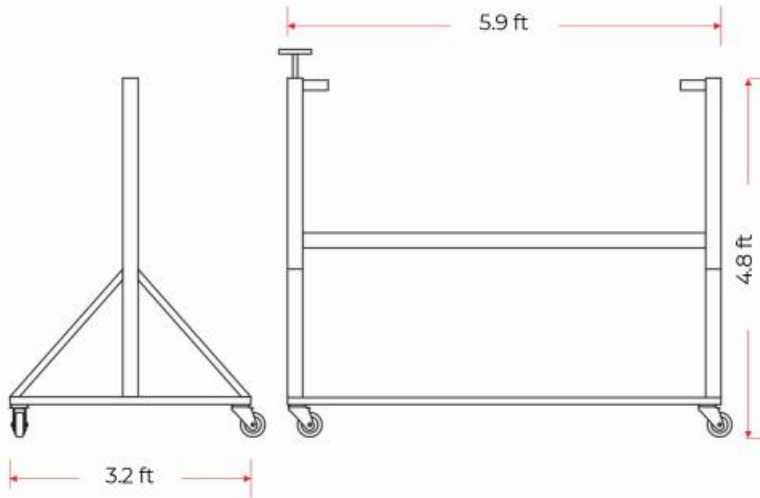

- Electric Arrow Board Weight** • 148.812 lbs
- Solar Arrow Board Weight** • Pending
- Electric Arrow Board Height** • 6.29 ft
- Solar Arrow Board Height** • 7.05 ft

<b>Fixed or Assembled Structure with swivel casters</b>	
Structure	<ul style="list-style-type: none"> <li>• 2 ½" x 1 ¼" hollow tubular structure of 18-gauge.</li> <li>• Industrial fixed and swivel casters of 4" (2 swivel and 2 fixed casters).</li> </ul>
Coating	<ul style="list-style-type: none"> <li>• Coating in fast dry bright traffic yellow enamel.</li> </ul>
Measurements	<ul style="list-style-type: none"> <li>• Length: 5.9 ft</li> <li>• Width: 3.2 ft</li> <li>• Height: 4.8 ft</li> </ul>
<b>Vandal Resistant Metal Panel with sealed cover</b>	
Structure	<ul style="list-style-type: none"> <li>• Hollow tubular structure surrounded by 18-gauge carbon steel sheet.</li> </ul>
Coating	<ul style="list-style-type: none"> <li>• Coating in fast dry bright black enamel.</li> </ul>
Measurements	<ul style="list-style-type: none"> <li>• Length 4.9 ft</li> <li>• Width 2.6 ft</li> <li>• Height 3.01 ft</li> </ul>

# LUMINOUS ARROW BOARDS

Code: FLE-15 / 18 o 25

## LIGHTING SYSTEM

Luminous Modules	<ul style="list-style-type: none"> <li>Clusters of ultra bright LEDs with 360° mica lens, butyl sealant and wiring for direct installation to 12V.</li> </ul>
Lighting Color	<ul style="list-style-type: none"> <li>Amber or Red</li> </ul>
LED Life Span	<ul style="list-style-type: none"> <li>100,000 hrs. (10 years).</li> </ul>
Light Intensity of each LED	<ul style="list-style-type: none"> <li>6500 mcd.</li> </ul>
Visibility Distance of System	<ul style="list-style-type: none"> <li>Around 3,280 ft.</li> </ul>

### Sequence System

Road Sequence	<ul style="list-style-type: none"> <li>Intelligent system by control card by push-button panel to display up to 08 sequences in 04 speeds.</li> </ul>
Work Sequence	<ul style="list-style-type: none"> <li>Flashing system by control circuit by push-button panel to display up to 03 sequences in 04 speeds.</li> </ul>

### Simple Power Supply System

- Electric power supply system to power direct current to 110V or 220V.
- Electronic power supply system by converter to supply 12V or 24V external battery .
- Solar power supply system with silicon photovoltaic panel of 50W, long-life battery.
- Rechargeable system of 12V-28AH to guarantee 10-24 hours of continuous functioning with full battery.

### Special Power System

- Hybrid Power Supply: 110-220V electric power supply + 127V-3000W Generator + 240W-12V Solar + Battery bank of 1500W-12V to guarantee their functioning for 24 continuous hours of 365 days of the year.
- Electronic power supply by 3KVA generator of manual pull start. Tank Capacity of 3.9 gal, guaranteeing at least 10 hours without fuel refilling. 02 available outlets, 01 thermal protection with (1/4) twist lock plug.

## LUMINOUS ARROW BOARDS

Code: FLE-15 / 18 o 25



**FLE-25-HIB**

25 signs arrow board with HYBRID power supply, red clusters and fixed structure.



**FLE-25-SOL**

25 signs arrow board with SOLAR power, red clusters and fixed structure.

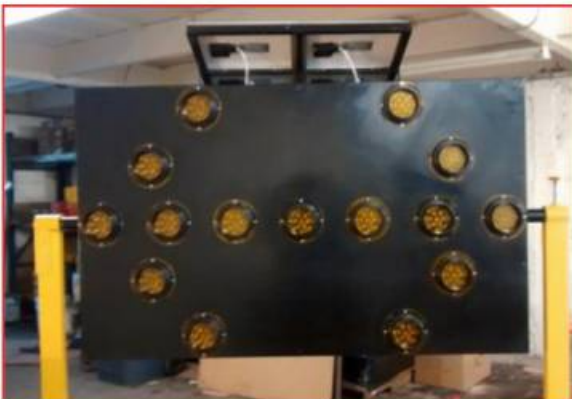

**FLE-15-SOL**

15 signs arrow board, bi-directional arrow board.



**FLE-15-ELEC**

15 signs arrow board, one direction, ELECTRIC power supply, red cluster and fixed structure.

## LUMINOUS ARROW BOARDS

Code: FLE-15 / 18 o 25



**FLE-18-SOL**

18 signs arrow board, SOLAR power supply, red clusters, assembled structure.



**FLE-18-ELEC**

18 signs arrow board, ELECTRIC power, amber clusters and assembled structure.



Packaging with cardboards, strap and transparent stretch film.



Packaging with cardboard and transparent stretch film.