

# ALUMINUM 200 ROUND PAVEMENT MARKER

Code: BA-200



## WHAT'S A ROUND PAVEMENT MARKER?

Horizontal signage device used in roads, highways or streets, that also work as speed bumps, stops and can delineate zones.

Impressive durability and elegance, guiding vehicle flow and providing safety to possible dangerous areas.

## FEATURES

- Designed to delimit and channelize vehicles.
- Ideal to confine public transport lanes, bike ways or to be used as speed bump.
- High resistance to vehicle collisions and low friction to tires.
- Manufactured to withstand heavy traffic.
- It doesn't require maintenance.
- Avant-garde design with multiple reflective sheeting that can be visible from any angle.
- Without cutting edges neither borders, to prevent damage to users.
- Adaptable to any pavement type.
- Easy installation with three boreholes, congruent with nails or extralarge anchors.

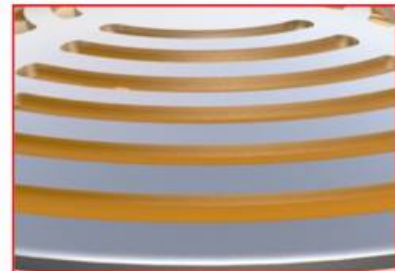
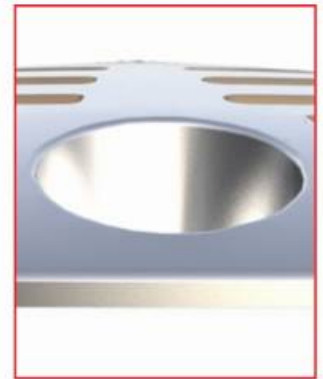

## 200 ALUMINUM ROUND PAVEMENT MARKER

Code: BA-200

### MEASUREMENTS

Dimensions and other measures are nominal and may vary by +/- 2%.

|  |  |
|--|--|
| <b>Manufactured in</b>                               | • Natural aluminum   |
| <b>Measurements</b>                                  | • Diameter: 7.8 in x height: 1.5 in                          |
| <b>Weight</b>  | • 1.278 lbs  |
| <b>Color</b>   | • Natural  |
| <b>Compressive strength (load)</b>                   | • 26,000 kg/cm <sup>2</sup><br>(369,806 lb/in <sup>2</sup> ) |
| <b>Impact Strength (ASTM D-256C IZOD) -18° -23°C</b> | • 10.68 j/m  |

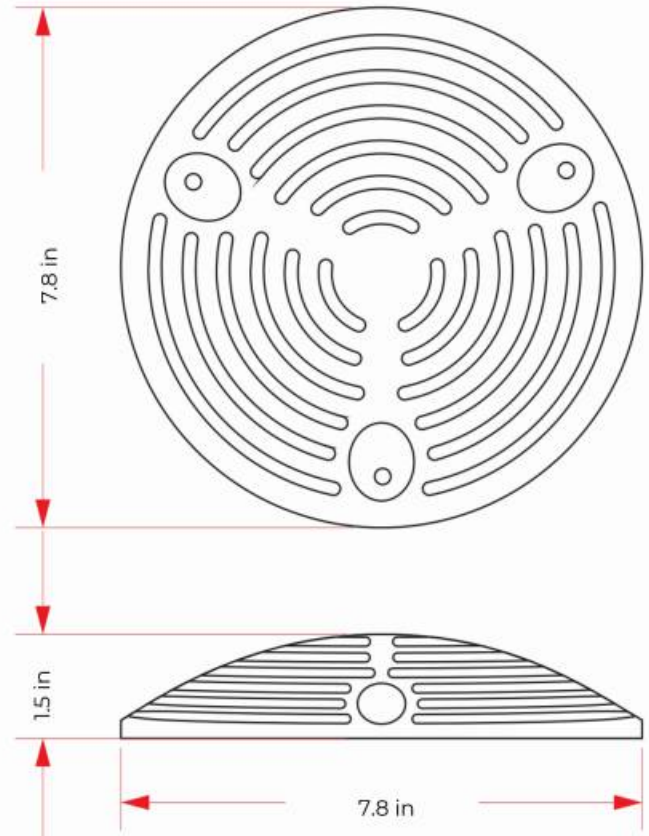

### INSTALLATION

First, prepare the surface, which must be dry and clean; then, mark the distribution of each pavement marker.

**Asphalt:** Mark the 3 boreholes, place each pavement marker and start to nail one by one. Secondly, apply epoxy resin on base (optional); make sure to avoid damage of pavement marker when hitting the nails, 3 nails of ¼" x 3".

**Hydraulic Concrete:** Mark a guide on concrete with a 3/16" drill bit to a 3" depth. Secondly, insert the three nails of ¼" x 3" by hitting them (add epoxy resin on base for a greater reinforcement, if desired).

**Extralarge Anchor:** Drill with a ¾" drill bit for concrete; then, borehole to a 7" depth. Secondly, insert the anchors on boreholes and place the pavement marker. Finally, insert the 3/8" flat washers with a 9/16" socket and tighten the 3 screws perfectly.

**DONE!**

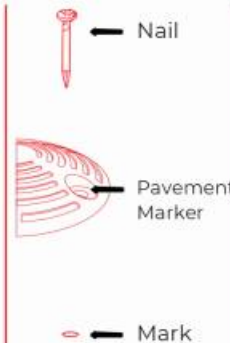

#### How to prepare epoxy resin:

1. Compound equal amounts of "a" + "b" substances.
2. Stir until a homogeneous mixture is obtained.
3. Once you are done, dispose of the epoxy resin residuals (it is for single-use only).