

MULTIVISTA TRAFFIC BUTTON

Code: BT-MUL

WHAT'S A TRAFFIC BUTTON?

A Traffic Button, Raised or Round Pavement Marker, also known as cat eye is a marker with retroreflection developed to delineate effectively the route in low-light conditions, or to use in parking lots, tactile guideways, et al.

This item is placed on pavement and it is used to separate traffic flow, indicate mobility, do drivers reduce their speed, delimit lanes, and other features of the Multivista Button are utility, discrete and convenient, due to its design doesn't distract driver from the road and attracts attention with their reflective elements.

Its reflection is made of spheres, increasing visibility at night.

Saves up to 6 times the cost of thermoplastic paint and economize a 50% in time and material.

Great utility in pedestrian zones, crossings, turns and to delimit parking lots.



FEATURES

- Manufactured in ABS in yellow, white, blue, red or green color, with UV-protection.
- Includes 5 metal acrylic reflective spheres with option to choose in one or two directions; and can be place in all kind of roads.
- Withstand all kind of vehicles, from bicycles to tow trucks, without cracking or losing its shape.
- Thanks to its materials and manufacturing methods this have a long lifespan, in addition, it has the option to include a bolt for better concrete fastening.
- The ABS bolt doesn't break, in case of detachment is possible its wearing, avoiding damage to tires.
- Easy to install and distinguished for its zero subsequent maintenance.
- High resistance to wear, friction, weight, humidity and rain.
- The installation of the button requires epoxy adhesive, which is distinguished for its resistance to heat, physical and chemical agents, due to its excellent adhesion, with a great durability.



MULTIVISTA TRAFFIC BUTTON

Code: BT-MUL

MEASUREMENTS

Dimensions, and other measures are nominal and may vary by +/- 2%.

Total

- Diameter: 3.9 in
- Height: 0.7 in

Reflector

- Acrylic sphere

Reflector color

- Amber, white, red, blue or green

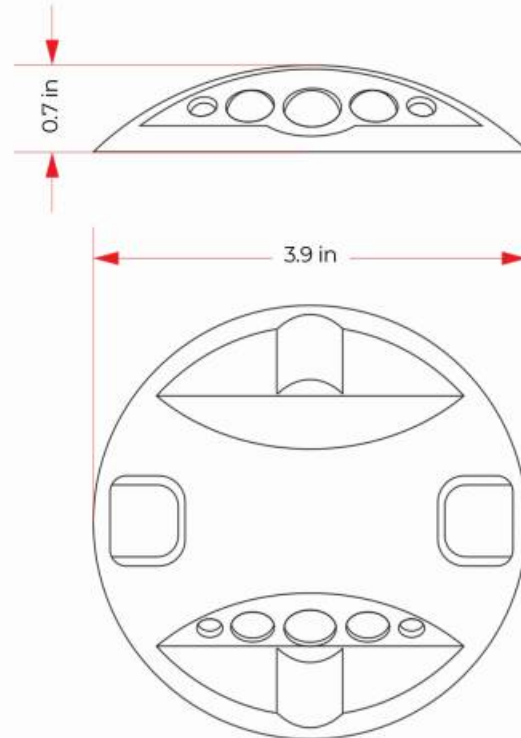

INSTALLATION

The installation of this Multivista Traffic button must be by hand to apply the epoxy adhesive.

1. Prepare the surface (must be clean and free of dust, grease and solvents).
2. Mark the place of each button (9.8 in in staggered formation).
3. Apply the epoxy adhesive all over the base of the button (approx. 3.5 oz.).
4. Place the button and pressure (it doesn't matter if you spill glue).

In case of using bolt

5. Drill with a ½" to a 3" depth.
6. Remove the dust and return to step 2.
7. Let it dry for approximately 2 hours.

Epoxy Resin Preparation

1. Compound equal amounts of "a" + "b" substances.
2. Stir until a homogeneous mixture is obtained.
3. Once you are done, dispose of the epoxy resin residuals (it is for single-use only).

