

TRAFFIC DRUM WITH LIGHT

Code: TSP-120-LUZ



RED LED

1 LED MAKES THE MAGIC OF TRAFFIC DRUM

Equipped with 1 latest generation ultra bright LED, this solar traffic drum is highly visible and appealing.

The intensified LED allow to be seen at long distances, with a synchronized lighting system that connects up to 131 ft among elements, without loosing the sequence in case that one fails.

Waterproof electronic system with IP68 protection.

Manufactured in high quality polyethylene in orange or yellow color, resistant to inclemency and UV rays for a prolonged durability.

Option to include reflective material to increase night visibility. Ideal to use in highways, prevent motorists from accidents, work zones, paths closed, delineate work areas, etc.

Nestable device, ease transport and storage.

FEATURES

- Generally used to close or channelize vehicle transit, due are highly visible thanks to their flashing light.
- It helps to guide the circulation within vehicle flow, such as parking lots to guide transit or delimit specific zones.
- Manufactured in a single piece with top grip for an easy manage and placement.
- Stackable, reducing transportation and storage costs.
- Option to include detachable heavy weight base of 13.2 lbs to increase stability by avoiding tilts caused by wind.
- Base manufactured in black polyethylene that filled with sand adds support to device (includes grip to load).
- Easy to clean and resistant to liquids and solvents.

SOLAR LIGHTING SYSTEM WITH HIGH LUMINOUS INTENSITY

- 1 ultrabright LED in red color.
- Flashing.
- Ø150 mm solar cell.
- 2 "AAA" rechargeable batteries of 1.5V-1,300 mAh.
- JVM power electronic circuit to synchronize flashing with other traffic drums.
- 5 hours of charge provide 16 hours of operation.
- Approximate LED life-span: 100,000 hours.
- LED approximate visibility distance: 328 ft.



Base with handle



Reflective rings



Solar cell



Top grip to manage

TRAFFIC DRUM WITH LIGHT

Code: TSP-120-LUZ

MEASUREMENTS

Dimensions, and other measures are nominal and may vary by +/- 2%.

Dimensions

- Upper diameter: 16.5 in
- Lower diameter: 19.6 in
- Height: 42.2 in
- Height with base: 42.9 in

Base Dimensions

- Height: 18.2 in
- Ø 23.0 in

Reflective tape

- 1 ring with 3.9 in height in white color

Traffic Drum Approx. Weight

- 7.716 lbs

Base Approx. Weight

- 13.227 lbs

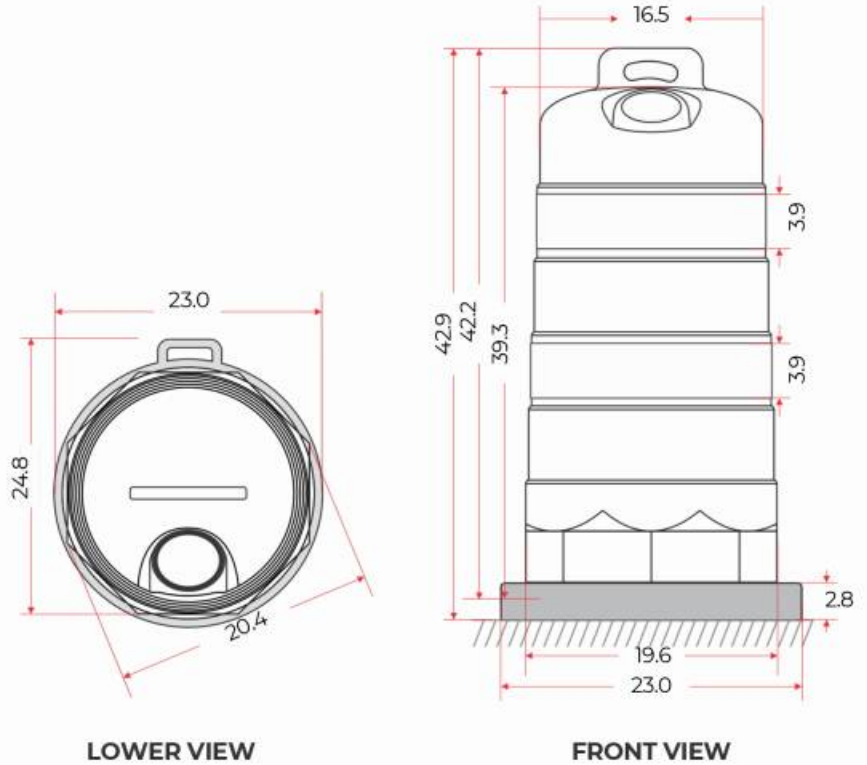

**Almost obligatory in
work zones without
public lighting**