

MAXI POST

Code: IT-MA-02 / IT-MA-03

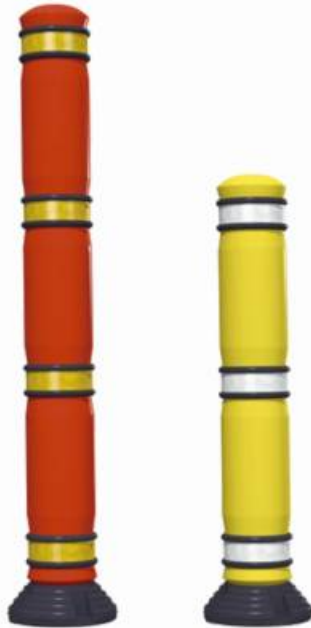

FEATURES

- Useful device in works, counter flows, diversions, forks and parking lots, et al.
- Resistant to environment and extreme temperature changes.
- UV protection.
- Withstand shocks and impacts.
- Circular base for greater stability with a center spring to make the post returns to its original position.
- High visibility color.
- High quality reflective stripes for a more visible device.
- Detachable pieces (threaded type) for an improved mount and change of size.
- Floor anchoring with 4 self tapping screws, flat washer and 5/16" expansion screws (not included).

SPECIFICATIONS

Dimensions and other measures are nominal and may vary by + / - 2%.

Manufactured in	• Medium Density Polyethylene
Body Color	• White, orange, yellow or black
Color de Reflective Stripe	• White or amber
Color of Rings and Base	• Black
Modules/Sections	• Height: 10.2 in • Diameter: 5.1 in
Base	• Height: 2.8 in • Diameter: 7.8 in
Rings	• Height: 2.6 in • Diameter: 4.9 in
Reflective Tape in Rings (optional)	• G.I.A.I

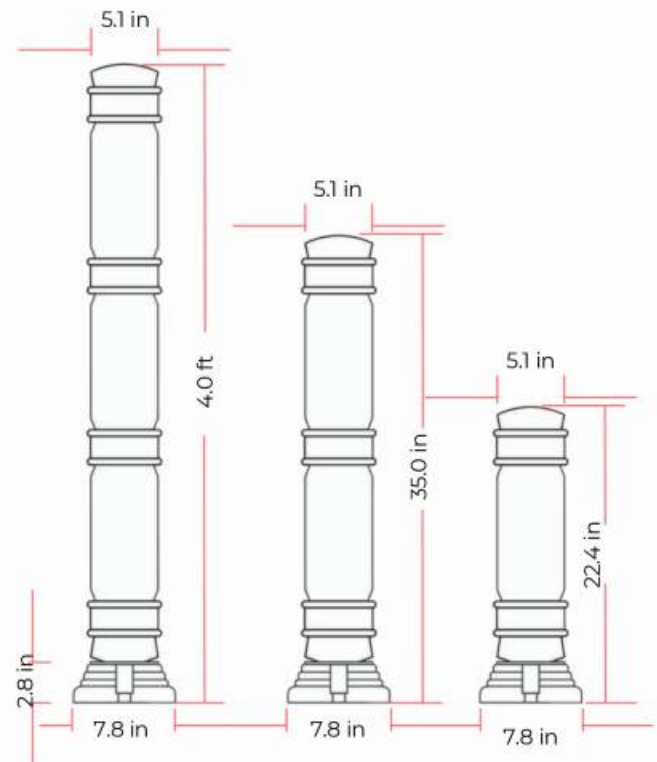

	Total Measurements
1 module post	22.4 in (height)
2 modules post	35.0 in (height)
3 modules post	4.0 ft (height)