

## ECOFLEX-125 DELINEATOR POST

Code: ECOFLEX-125

### ECOFLEX - 125



Delineator posts are signage devices that demarcate, delimit, and guide the transit of roadways or parking lots, used specifically to channelize bike ways and forks.

Their main function is to avoid vehicles invading prohibited zones; limit or line reserved zones, these also create pedestrian crossings.

### FEATURES

- Ecoflex 125 delineator post is manufactured in poliflexy® to be rigid enough to maintain its position and recover if impacted.
- Line color: yellow, orange, green, blue, white, black.
- Delineator posts have 4 reflective rings to guarantee more visibility in dark environments.
- Body manufactured in one piece, without extra caps to avoid detachment.
- Base with gussets made of the same material, increasing support when impacted.
- Base with 3 boreholes for a safe and easy installation.
- Fastening: it is suggested to use 3 screws and 3 extralarge anchors, providing extra security.
- Add heavyweight base for a portable post, avoiding falls.
- Base manufactured in black polyethylene; with included handle for an easy maneuverability.



Reflective Sheeting



Anchoring



Gussets and boreholes

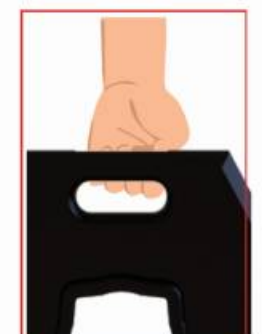

Handle

# ECOFLEX-125 DELINEATOR POST

Code: ECOFLEX-125

## MEASUREMENTS

Dimensions and other measures are nominal and may vary by +/- 2%.

- |                                  |  |
|----------------------------------|--|
| <b>Total</b>                     | <ul style="list-style-type: none"> <li>• Height: 4.1 ft</li> <li>• Sup ø. 3.5 in</li> <li>• Base ø 8.4 in</li> </ul> |
| <b>Base</b>                      | <ul style="list-style-type: none"> <li>• 15.7 x 18.1 x 1.5 in of height</li> </ul>                                   |
| <b>Reflective Sheeting</b>       | <ul style="list-style-type: none"> <li>• 4 rings</li> </ul>  |
| <b>Reflective Sheeting Color</b> | <ul style="list-style-type: none"> <li>• White, amber or two colors</li> </ul>                                       |
| <b>Peso hito aprox.</b>          | <ul style="list-style-type: none"> <li>• 3.6 lbs</li> </ul>  |

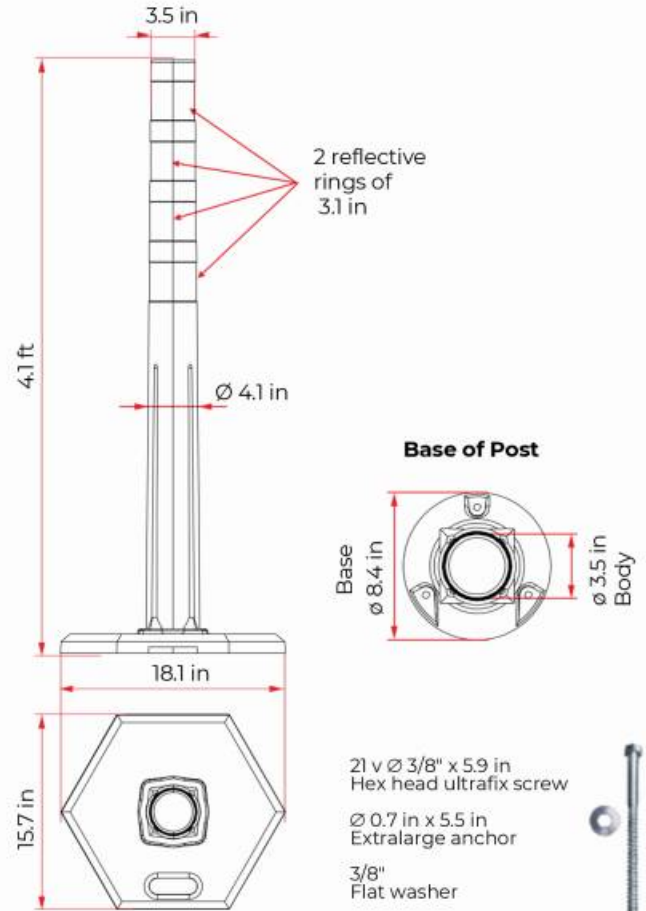

## ANCHORING

1. Mark the position of the boreholes, using the base of a delineator post as a template.
2. Drill the designated area with a 3/4" drill bit for concrete to a 6" (15.24 cm) depth.
3. Insert the anchors on the boreholes and place the delineator post.
4. Put the 3/8 x 5.9 in screws with flat washers and tighten the 4 screws using a 9/16" socket wrench.

**DONE!**

Note: Add epoxy resin in boreholes for a better installation, if desired.

