

LANE SEPARATOR WITH POLIFLEXY VERTICAL PANEL

Code: PCP-70

WHAT'S A LANE SEPARATOR WITH VERTICAL PANEL?

It is a parking stop or lane separator with a flexible vertical panel that helps to the lane division.

Used to guide diversions, temporary counter flow lanes or to condition cars to respect the exclusive lane.

Divide restricted areas and road sectors for the cyclist protection.

Mainly suggested in avenues where is necessary to reduce speed and intended to install a bike lane.

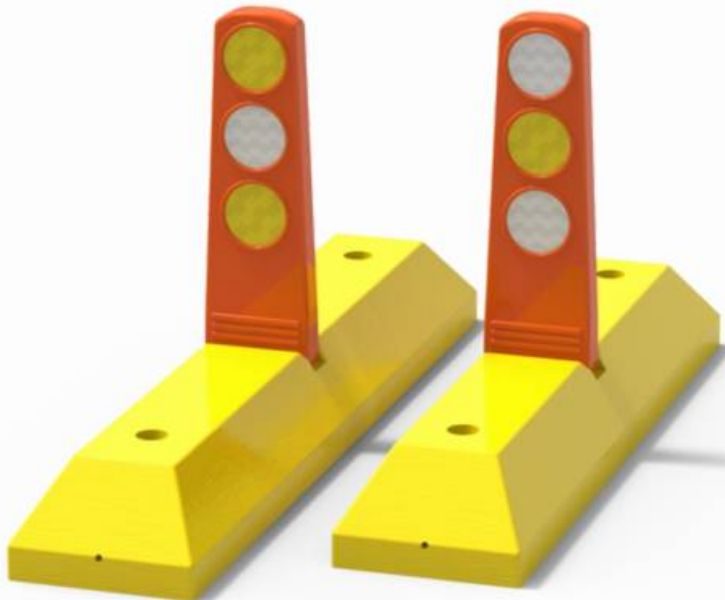

FEATURES

- Lane separator with flexible vertical panel and self-recovering system caused by impacts.
- Ideal for counter flow lanes and diversions in temporary works.
- High visibility during day and night.
- With UV protection.
- Design that allows an easy transport due to its lightweight.
- Without cutting edges, preventing the damage of vehicles
- Lane separator manufactured in high density polyethylene with Poliflexy® panel.
- Lane separator with two measures 27/31 in.
- It is installed with 2 anchors; can be drowned in epoxy resin for a better fastening.



LANE SEPARATOR WITH POLIFLEXY VERTICAL PANEL

Code: PCP-70

MEASUREMENTS

Volumes, dimensions and other measures are nominal and may vary by approximately 2%.

Total

- Length: 27.5 or 31.4 in
- Width: 6.2 in
- Height: 15.7 in

Reflective Sheeting

- 3 circles of Ø 2.1 in per face

Reflective Sheeting Color

- White or amber

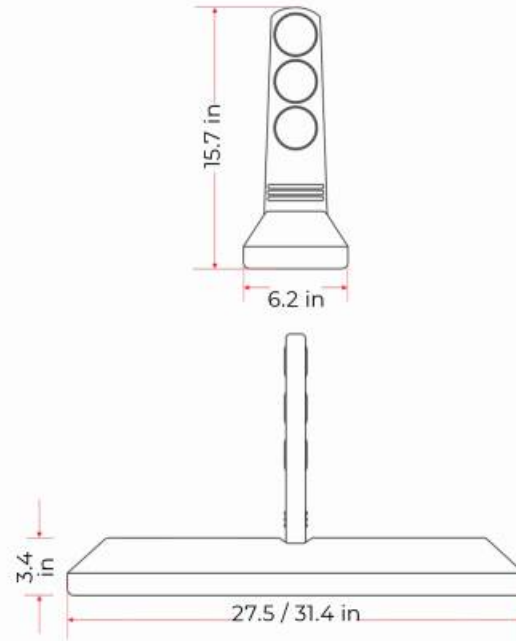

ANCHORING PROCEDURE

1. Mark the boreholes using the lane separator as a guide.
2. Drill with a 1/2" drill bit for concrete to a 3" depth (for guidance only).
3. Place the device and insert the anchors.
4. Nail the anchors with a 6 lbs mallet until you reach the bottom.

