

## REFLECTIVE CENTER LANE SEPARATOR

Code: CCR-183

### FEATURES

Industrial Design  
Registration before the  
IMPI  
Exp. MX-f-2008/001244



- Reduce speed up to 4.9 miles / 7 hr.
- Resistant to shocks and impact due its robustness.
- Its components are eco-friendly.
- UV protection.
- Easy to transport due its lightweight and shape.
- Long life-span.
- Reduce risk on roads

**MAINTENANCE:** It doesn't need coating neither special treatment, besides it is easy to clean of any waste.

**DURABILITY:** It can maintain an excellent usage conditions for long time, even in inclemency, wetlands, saline or acidic zones.

Superior life span to wood, metals and other materials.

### SPECIFICATIONS

Dimensions and other measures are nominal and may vary by +/- 2%.

<b>Total</b>	<ul style="list-style-type: none"> <li>• Length: 6.0 ft</li> <li>• Height: 2.0 in</li> <li>• Width: 11.0 in</li> </ul>
<b>Manufactured in</b>	<ul style="list-style-type: none"> <li>• High density polyethylene</li> </ul>
<b>Color</b>	<ul style="list-style-type: none"> <li>• Yellow</li> </ul>
<b>Anchors</b>	<ul style="list-style-type: none"> <li>• ½" x 13.5"</li> </ul>
<b>Thermal Resistance</b>	<ul style="list-style-type: none"> <li>• 0960 a 0.965 gms X cm<sup>3</sup></li> </ul>

### INSTALLATION:

- 5 anchors (included)
- Bore with a 3/8 drill on the place to set the lane separator

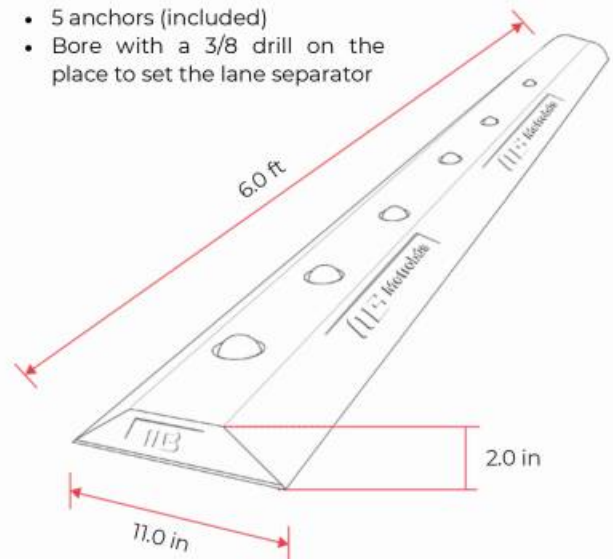

It doesn't breaks, cracks neither rusts, 100% permeable, resistant to alcohols, solvents and environmental temperature changes; and is totally recyclable.