

STAINLESS STEEL ATHENA BOLLARD

Code: BO-AT-INOX-F / BO-AT-INOX-A

WHAT'S A BOLLARD?



Fixed Bollard

Flexible Bollard

Solar device of prevention and warning, placed strategically to avoid motorists invade public spaces intended for pedestrians, separating sidewalk and road. The intelligent design ensure a high visibility and attract the attention of users.

This bollard is an effective solution, providing a clear and visible barrier that eases the transit organization, and protect all the road users. Post manufactured in 11-gauge stainless steel, natural color. Device can have a finish of electrostatic paint available in black, red, orange or green.

The design incorporates a cap that improve night visibility and two golden rings that stand out the modern aesthetic. It combines functionality, resistance and visibility, offering an efficient solution for organization and safety.

Excellent for government esplanades, as malls, hospitals, entrance of hotels, airports and others.

FEATURES

- Athena bollard of stainless steel is a harmonious, flashing and fine solution to delineate public spaces and road safety.
- Available in two versions: fixed and flexible.
 - Fixed: Stainless steel base anchored to floor, designed to provide a permanent delineation without movement.
 - Flexible: ABS base with inner system that allow bollard to tilt if hit, recovering automatically its vertical position.
- Ideal for situations where is required flexibility and resistance to impact.
- Luminous head of translucent white polyethylene with top of stainless steel.
- It charges during day, turning ON at night, automatically.

LUMINOUS SYSTEM

- Solar cell: 85 mm
- Battery: Lithium polymer
- LED: 12 ultra bright
- Available color: Amber, white and red
- Light type: Flashing
- Synchronization Options: Bollards can synchronize for a coordinated lighting.
- Durability: High resistance to humidity conditions, designed to withstand extreme temperature changes.



STAINLESS STEEL ATHENA BOLLARD

Code: BO-AT-INOX-F / BO-AT-INOX-A

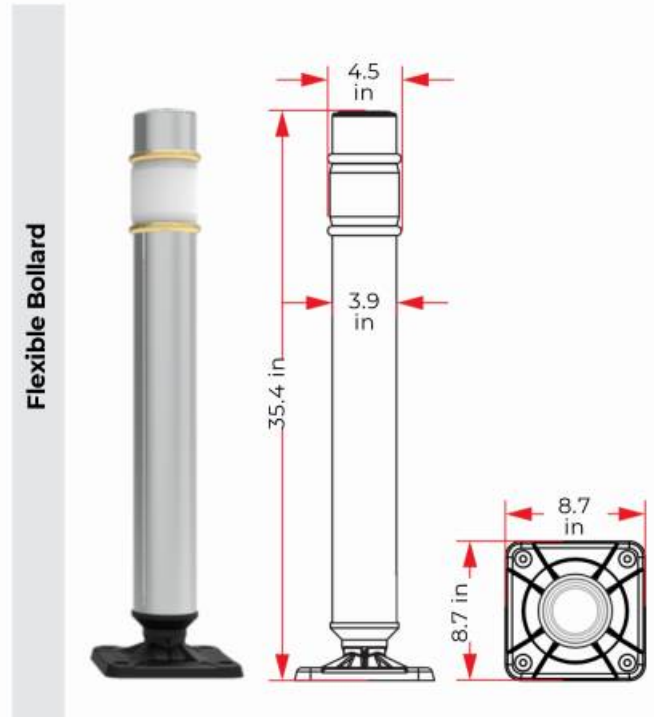
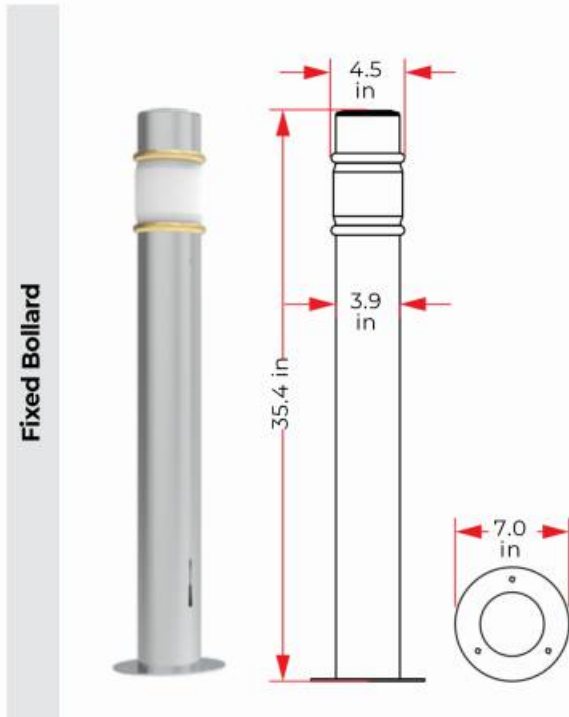

MEASUREMENTS

Dimensions and other measures are nominal and may vary by + / - 2%.

	Fixed	Flexible
Body Diameter	4.00" (10.16 cm)	4.00" (10.16 cm)
Base Diameter	7.0" (18.0 cm)	8.7 x 8.7" (22.3 x 22.3 cm)
Total Height	35.4" (90.0 cm)	35.4" (90.0 cm)

ANCHORING

1. Mark the boreholes in the position of the bollards.
2. Drill with a 3/4" drill bit for concrete to a 7" depth.
3. Insert the extralarge anchors in every hole.
4. Mount the bollard, place the 3/8" screw/flat washer, tighten with a 9/16" socket wrench and...
DONE!



Anchoring

Hex Head Ultrafix Screw
Ø 3.8" x 5.9"

"Extralarge" Anchor
Ø 0.7" x 5.5"

