

STREET SIGN 91

Code: NOM-91

WHAT STREET SIGNS ARE?

Indicate users the names and road types, demarcation where you are located, traffic way and in some cases numbering of houses.

Placed on existent or own pole/post at the corner of urban junctions.

Basic information includes:

1. Road Type: As avenue, street, and others.
2. Name of the road: option to use common abbreviations, in case caption doesn't fit.
3. Type and name of neighborhood.
4. Zip Code.
5. In some places is added an emblem and name of demarcation.
6. And in some cases, house numbering.
7. Option to add QR code of geo-location to explore more about the zone where you're located.

FEATURES

- Two faces, ideal spaces that allow to read and guide perfectly the places where we are and where we go.
- With 2 galvanized sheets of 24-gauge with reflective background, texts in vinyl or digital printing, according to project.
- Body that allow to be stowed, making it more affordable for transportation and storage.
- Manufactured in the highest quality polyethylene, with great durability, maximum resistance and UV protection.
- RHS post of 2"x2"x 9.8 ft of height, steel plate base of 7.8 x 7.8 in x ¼" thickness, reinforced with gussets, cap in pyramid shape with black color, and four boreholes for its installation.
- Can have 1, 2 or more signs, according to project.
- Easy installation (anchored to floor).

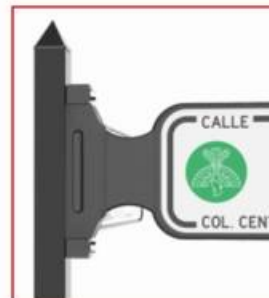

STREET SIGN 91

Code: NOM-91

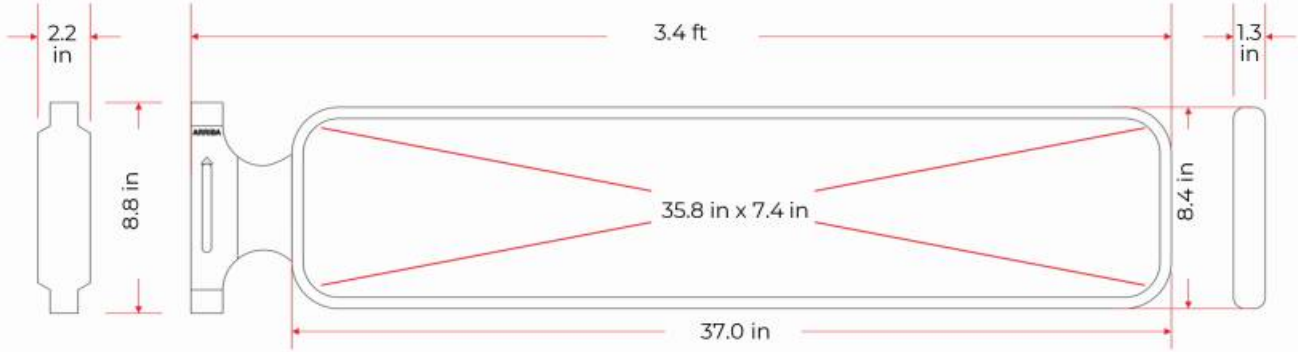

MEASUREMENTS

Dimensions and other measures are nominal and may vary by + - 2%.

- Manufactured in**
 - High density polyethylene
- Color**
 - Black
- Weight**
 - 1.000 kg (2204 lbs)
- Background**
 - 1 galvanized sheet of 24-gauge per side (sign/label)
- Plate measures**
 - 35.8 x 7.4 in
- General measures**
 - Length: 3.4 ft
 - Width: 2.2 in
 - Height: 8.8 in



Staples and support bracket attach to post