

GLOBAL FORTE SIGN WITH ADDITIONAL INFORMATION

Code: SE-BA-6076



FEATURES

- Lightweight body manufactured in a single-piece of black high density polymer to one face.
- Resistance to inclemency and temperature changes, with UV protection.
- Humidity-proof and recyclable; long life span, due it doesn't rusts.
- Vandal-proof sign made of plastic material, without resale value neither used for other purposes, avoiding thefts.
- Stackable, reducing transportation and storage costs.
- Easy installation; Posteflex® of 2" x 2" with inner tubular reinforcement or steel RHS.
- Submitted to 80° test.

LABEL

- **Restrictive:** Prismatic reflective background in white, texts and fillet in opaque black vinyl, ring in red.
- **Warning:** Prismatic reflective background in yellow, texts and fillet in opaque black vinyl.
- **Recreation:** Prismatic reflective background in blue, texts and fillet in opaque white vinyl.
- **Service:** Prismatic reflective background in blue, texts and fillet in opaque white vinyl.
- Guaranteed adherence to vinyl.

Note: Customization with institution logo in digital printing if desired.

WHAT AN EXCLUSIVE SIGN IS?

- Exclusive board with exceptional dimensions that fusions main sign and additional board.
- These signs are fixed on posts.
- With symbols and captions to indicate users, both urban and rural areas, the existence of physical limitations, regulatory prohibitions or traffic, prevention, service, tourism or protection indications.
- Exclusive signs are designed with the perfect size to integrate an additional device in a rectangular shape, improving clearness in signage.
- Ideal board for WARNING, RESTRICTIVE, TEMPORARY TRAFFIC CONTROL, RECREATION, SERVICE AND INCIDENT MANAGEMENT signs.
- Require further information about the over 1,100 options of sign with additional information.



GLOBAL FORTE SIGN WITH ADDITIONAL INFORMATION

Code: SE-BA-6076

MEASUREMENTS

Dimensions and other measures are nominal and may vary by +/- 2%.

General Measurements

- Length: 25.1 in
- Width: 1.9 in
- Height: 31.4 in

Vinyl Dimensions

- Length: 24.0 in
- Height: 29.9 in

Reflective Sheeting:

- Depends on the design

Posteflex® Dimensions

- Width: 1.9 x 1.9 in
- Length: 1.5 in
- Thickness: 0.19 in
- Width: 1.9 x 1.9 in
- Length: 9.8 ft
- Thickness: 0.11 in

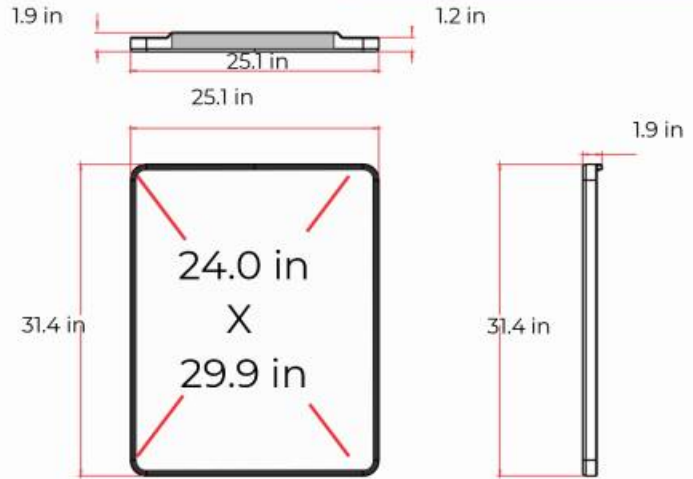

POSTEFLEX®

Height

In urban and interurban roads, the lower part of board is to 8.2 ft above sidewalk level.

