

We have passed to the next level!

Features

- Signage boards; designed according to 034-SCT2 standard to guarantee visibility and compliance of traffic regulations.
- Integrates latest generation LEDs, maximizing visibility with many combinations.
- Set in one or two Posteflex®, guaranteeing resistance to adverse climate conditions; including straps in black polyethylene and screws for a safe fastening.
- Optimal size for signs to be easy to identify at distance.
- Board can turn to 45° to make a warning sign.
- In addition, it has 4 extra LEDs in every end to increase visibility.
- Types of signs: Warning: it warns about the possible risks. Restrictive: indicate prohibitions or traffic limitations. Temporary traffic control: inform about the works in the road. Recreation: sign places of interest. Service: indicate the available services in the zone. Safety: for emergency situations.
- IP68 waterproof electronic system.

Technical Features

- Manufactured in one side of black color polyethylene.
- Posteflex® in yellow or grey color.
- Resistance to inclemency and temperature changes, with UV protection.
- Anti-humidity and recyclable; long life span due it doesn't rusts.
- Vandal-proof, due plastic material has zero resale value, neither work for other usages, avoiding thefts.
- Stackable, reducing transportation and storage costs.
- Easy installation; posteflex® with tubular reinforcement on inner part or steel RHS.

Solar Systems

- Solar power supply panel on top part.
- LEDs with conical optics and mirrors causing light expands in all the sign.
- 1.2 V batteries.
- JVM electronic power supply circuit that synchronizes flashing of signs.
- It charges during 6 hours under the sun, it lasts 24 hours in flashing mode.



Dimensions and other measures are nominal and may vary by 2%.

Measures in: in

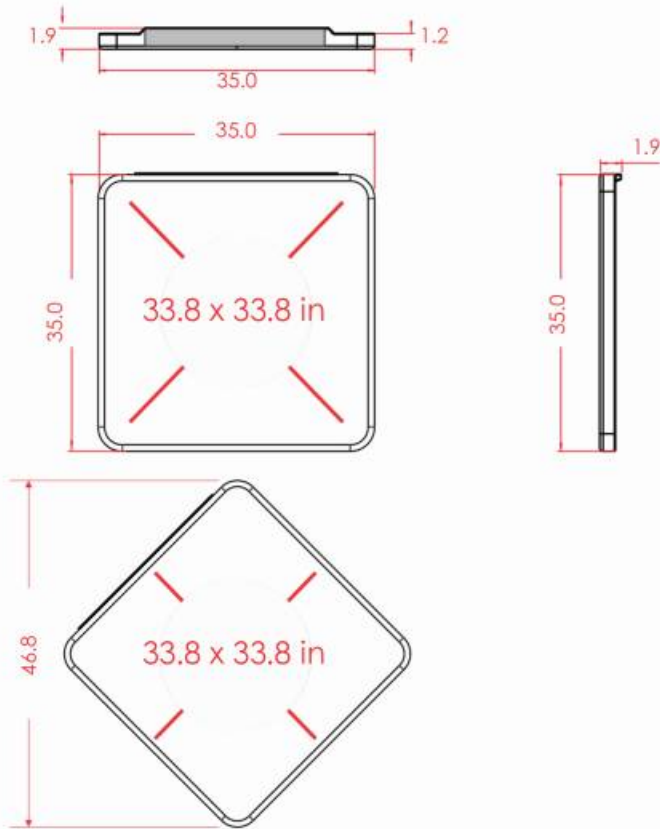

Measures

General measures	Length: 33.0 in
	Width: 2.7 in
	Height: 33.0 in
Vinyl Dimensions:	Length: 33.8 in
	Height: 33.8 in
Diamond Dimensions:	Length: 46.8 in
	Height: 46.8 in
Reflective Sheeting:	Depends on the design
Posteflex®	Width: 1.9 x 1.9 in
	Length: 13.1 in
Dimensions:	Thickness: 0.19
	Width: 1.9 x 1.9 in
	Length: 9.8 ft
	Thickness: 0.11 in

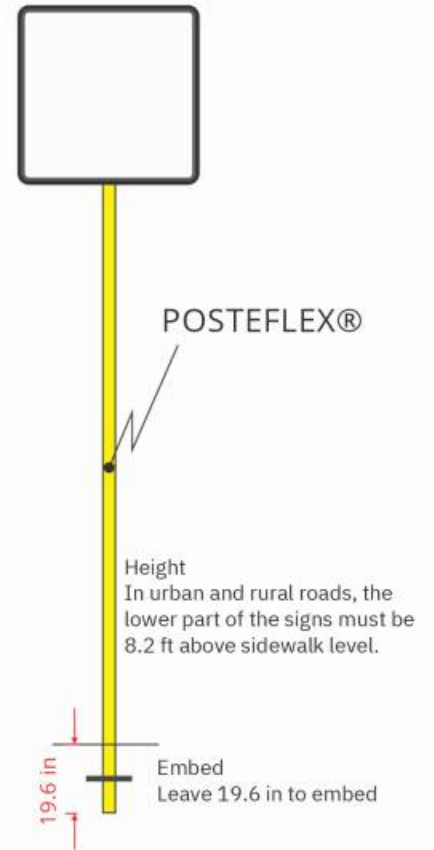

Modes



- Label**
- Restrictive: Reflective background "A or B" type, as required; in white color, texts and fillet in opaque black vinyl, ring in red color.
 - Warning: Reflective background "A or B" type, as required; in yellow color, texts and fillet in opaque black vinyl.
 - Recreation: Reflective background "A or B" type, as required; in blue or brown color, texts and fillet in opaque white vinyl.
 - Service: Reflective background "A or B" type, as required, in blue color, texts and fillet in opaque white vinyl.
 - Temporary traffic control: Reflective background "A or B" type, as required, in orange color, texts and fillet in opaque black vinyl.
 - Guaranteed vinyl adherence.
 - Note: It can customize with institution logo, if desired, this is printed digitally.