

## PREMIUM SIGN Suspended

Code depends on the selected product

### WHAT ARE PREMIUM SIGNS?

- High profile, elegant and great quality sign.
- Can be used in indoors and outdoors.
- Created with curved front labels.
- Designs may vary: attached or suspended.
- Composed by natural, anodized, satin, curved and extruded aluminium profile.
- Suspended premium signs are used with covers specially designed to create one or two face labels.
- Polyethylene supports and ceiling connectors are attached with a 1/16"-gauge galvanized steel cable ; which accept standard size profile installed in one piece or set, creating different combinations.
- Frames accept any flexible film in digital printing or label, in addition can have photo-luminescence, helping to be seen without light.
- Anti glare covers available in matt or bright finish.
- This innovation allows an easy set and detachment for maintenance or change purposes.
- If modification if required, only label can be changed without taking off signage.
- With fine and excellent quality that provide a prolonged life span due it doesn't rusts.

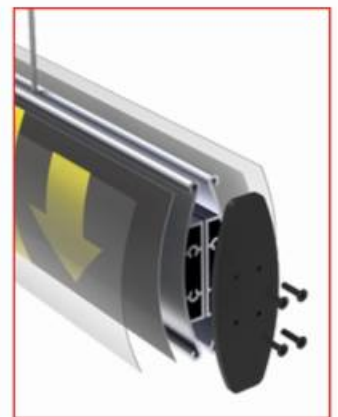

# PREMIUM SIGN

## Suspended Totem

Code depends on the selected product

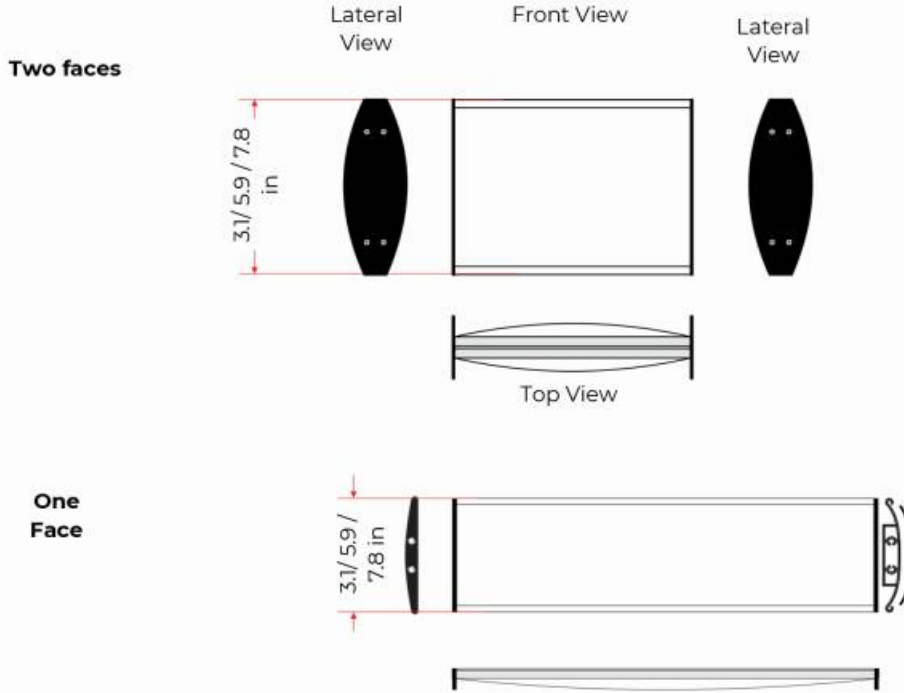

### MEASUREMENTS

Dimensions and other measures are nominal and may vary by +/- 2%.

**One or Two Faces**

- Length: 15.7 in to 4.1 ft | Height: 3.1 in
- Length: 7.8 in to 4.1 ft | Height: 5.9 in
- Length: 7.8 in to 4.1 ft | Height: 7.8 in

**Label/Sign**

- Can be photo-luminiscent

