

DOUBLE PLANTER

Code: TSSM-M2P



WHAT'S A DOUBLE PLANTER?

It's a modular system that can be used in any building, house or room.

Thanks to its storage capacity and water re-absorption that saves time of caring to grow vegetables, as maintain fresh plants without the necessity of water for indefinite period.

Ideal for any outdoor or indoor space where is desired to place a plant. It is commonly used in plazas, roof top, gardens, homes, offices, et al.

Customization: According to your needs, this can be label with the name of the material made of or with the institutional logo.

FEATURES

- This device is manufactured in one piece of medium density polyethylene thanks to the injection process.
- It doesn't has riveted parts, preventing tensile strength point or fragility that can affect to its resistance and can be reflected on its usage.
- Resistant to climate conditions.
- UV protection.
- Double wall for water reserve.
- 7 holes for a water re-absorption.
- Drainage plug.
- It doesn't require special installation for its placement.

More green areas means more help to win the fight against Global Warming

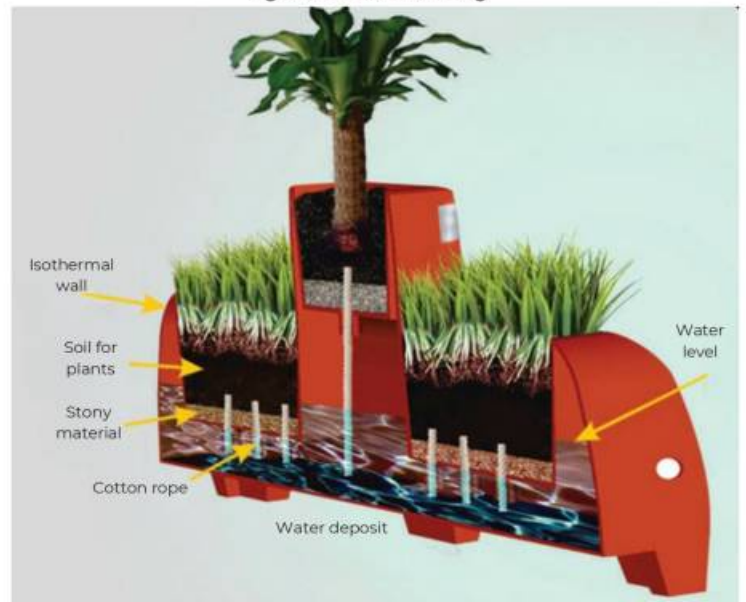

DOUBLE PLANTER

Code: TSSM-M2P

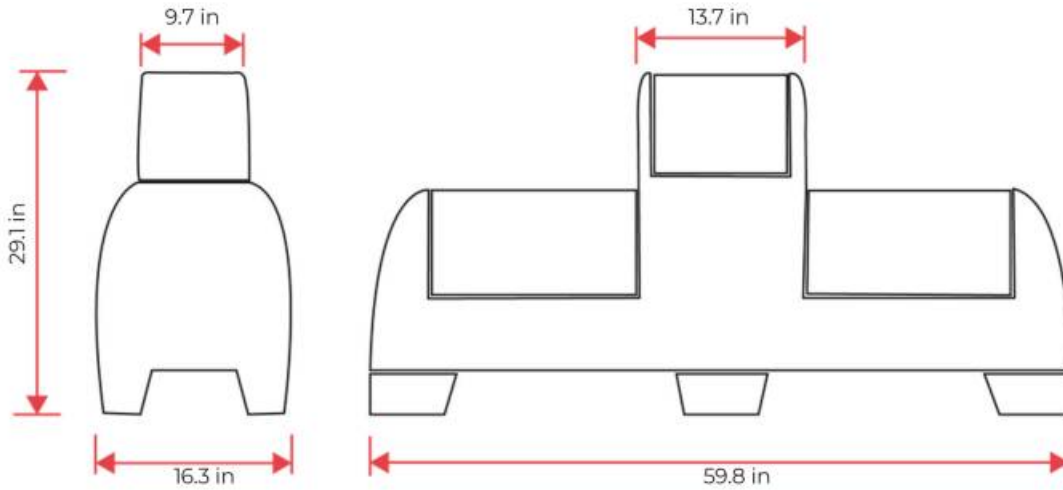

MEASUREMENTS

Volumes, dimensions and other measures are nominal and may vary by approximately 2%.

Piece Measurement	<ul style="list-style-type: none"> • Length: 59.8 in • Width: 16.3 in • Height: 29.1 in
Manufactured in	<ul style="list-style-type: none"> • Medium Density Polyethylene
Water Capacity	<ul style="list-style-type: none"> • 2.6 gal
Life Span	<ul style="list-style-type: none"> • 10 years
Color	<ul style="list-style-type: none"> • Chocolate