









STREET SIGN



390

**TRANSFORM YOUR STREET SIGNS:
TAKE THEM TO THE NEXT LEVEL!**

TABLE OF CONTENTS

-  **01** WHAT IS IT? 2
-  **02** FEATURES 3
-  **03** MEASURES 4
-  **04** INSTALLATION 6
-  **05** LABEL/SIGN EXAMPLES 7
-  **06** CONTACT US 9



WHAT IS IT?

Street Signs are perfect to improve signage and inform pedestrians.

In addition, these are designed in one piece and include support to anchor.

Our street signs are 100% water and vandal-proof.

These are highly recommended for hotels, malls, tourist centers or self-service chains.

We guarantee a maximum resistance and durability. Ideal for cities and municipalities with great pedestrian flow or meeting points.

We have three versions: 390 with light, solar 390 and New City 390.

390 WITH LIGHT



SOLAR 390



NEW CITY 390

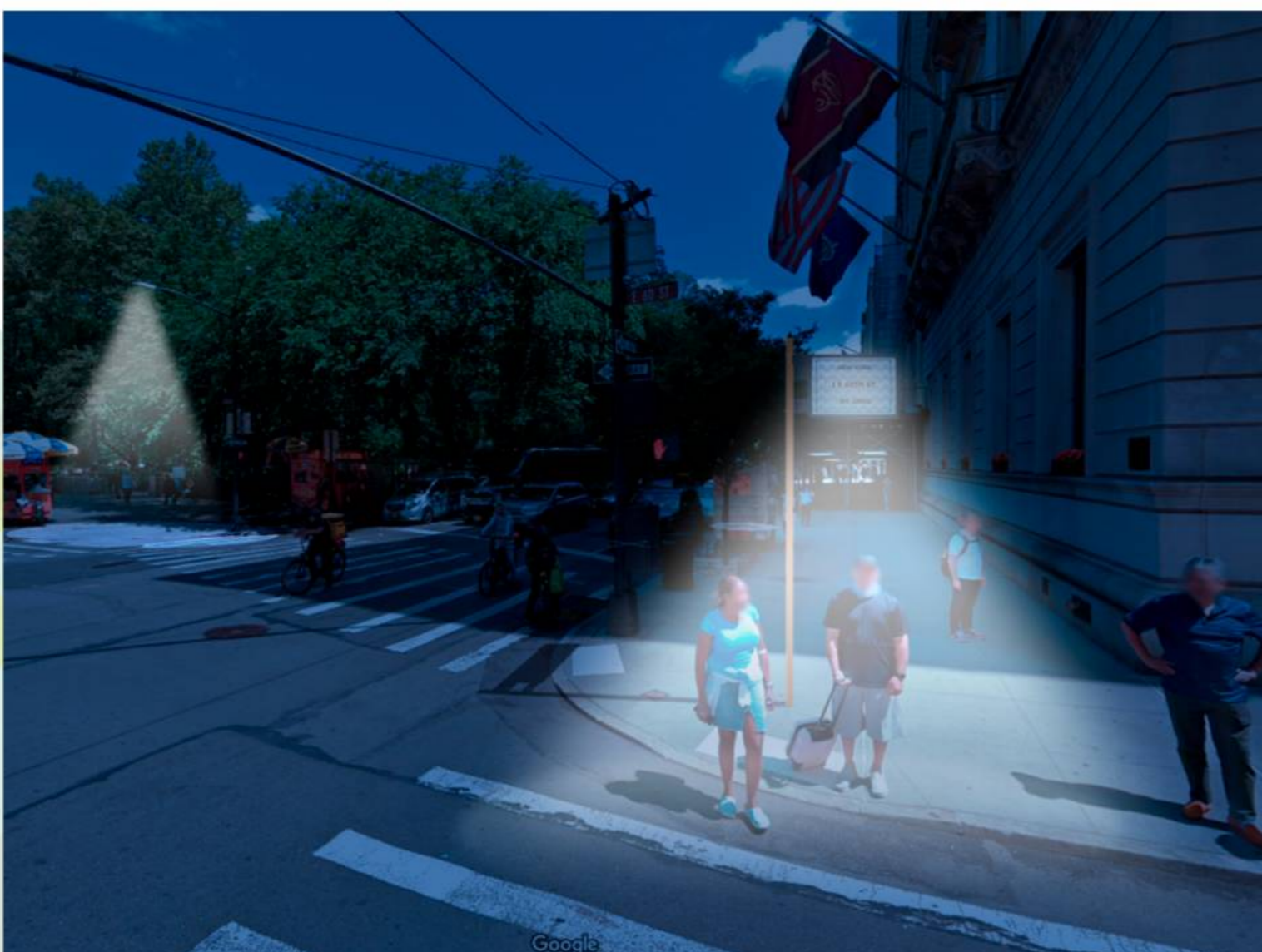

FEATURES

STREET SIGN 390 WITH LIGHT

- Street sign present a lightweight body manufactured in RCB polymer in white color, allowing an optimal light transmission.
- Our LED technology with low-energy consumption contributes to environmental respect. The ON/OFF system is operated by a photoelectric- electronic sensor, ensuring light efficiency that adapt to specific needs.
- Thanks to the high luminosity, light a 6 meter radius area.



SOLAR STREET SIGN 390

- Integral Design: Manufactured in RCB polymer in white color, unique structure with 2 joins, for a firm fastening to pole, providing a flawless aesthetic.
- Advanced Technology: JVM power system and 3V, 1.65W solar panel with "AAA" batteries of 1100mA, guaranteeing an optimal performance.
- Sustainability; 100% recyclable, contributing to environmental preservation.



NEW CITY 390 STREET SIGN

- Manufactured in RCB polymer in black color, molded in one piece, with two straps for a safe and uncomplicated installation. Street Sign transforms into a vandal-proof element, ideal to indicate locations and to be used as an advertisement.
- Sustainability: 100% recyclable, contributing to environmental preservation.



MEASURES

Top View

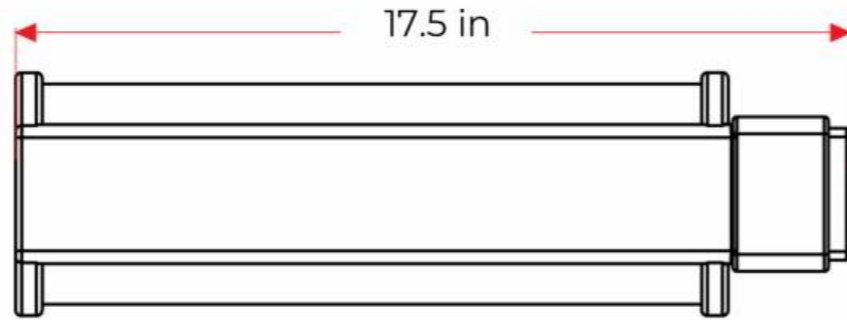

Front View

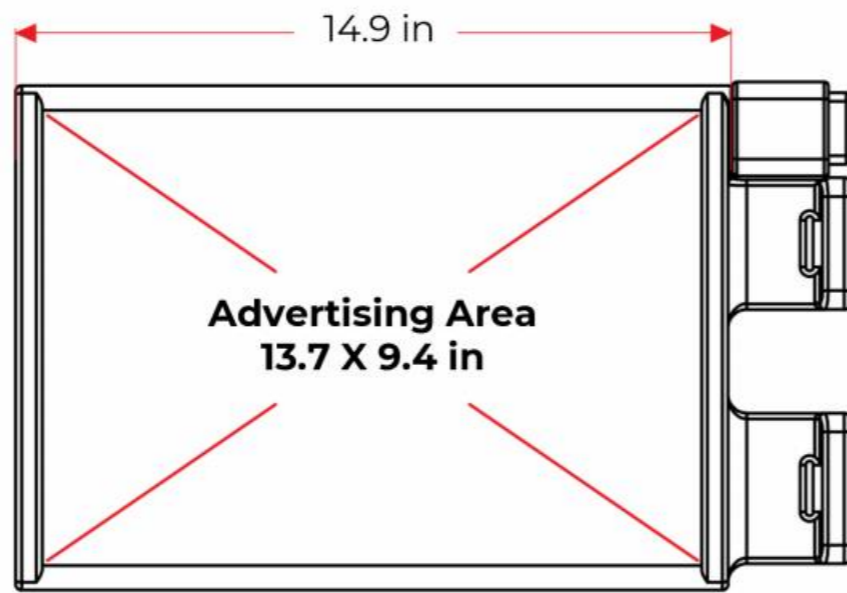

Side View

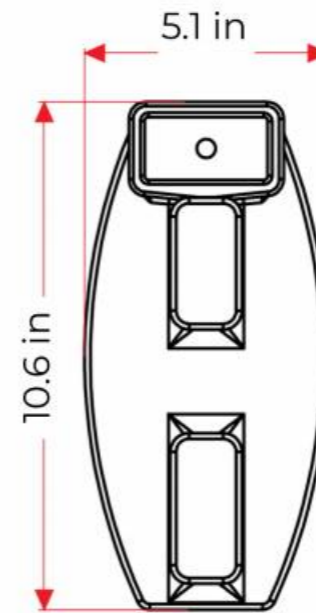

Lower View

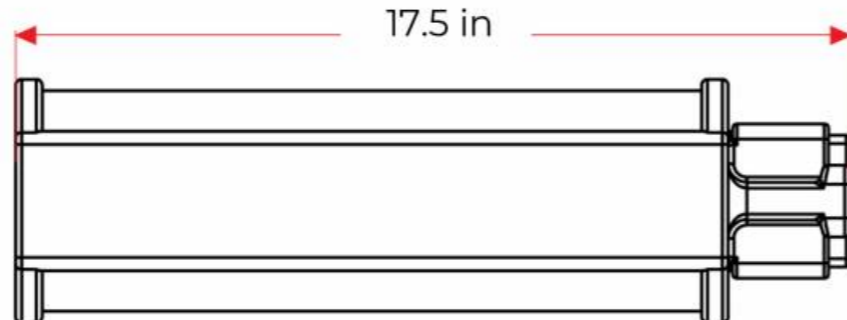

390 WITH LIGHT

Top View



Front View



Side View



Lower View



390 NEW CITY

Top View



Front View



Side View



Lower View



MEASURES

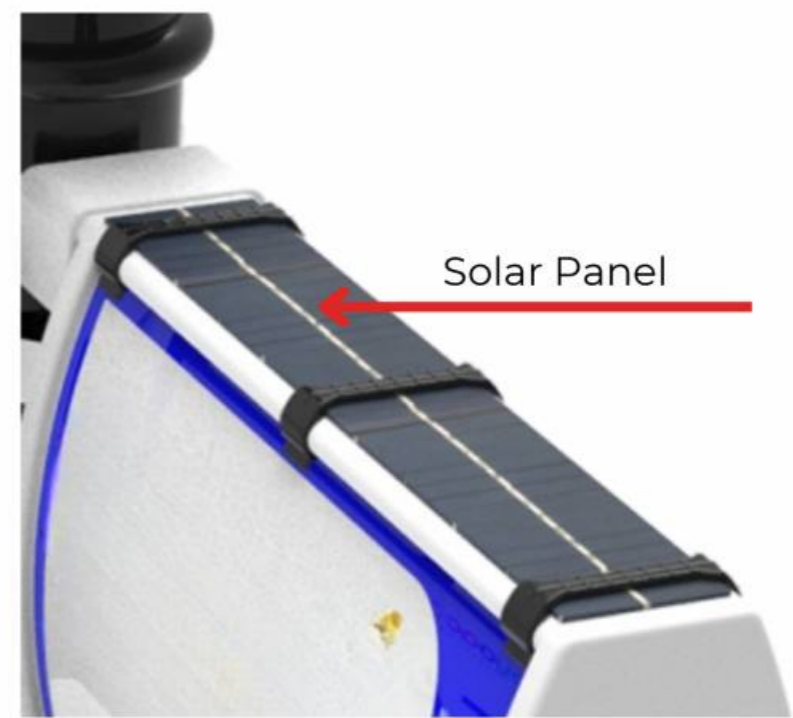
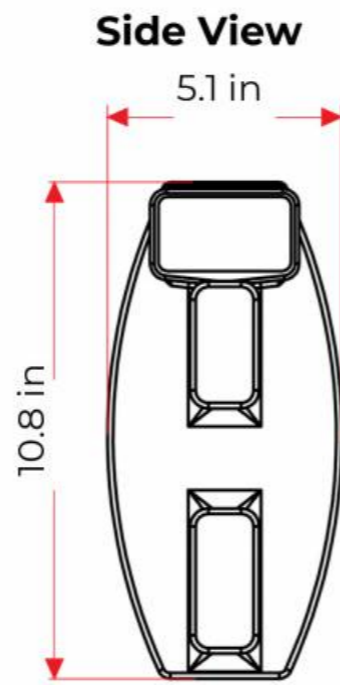
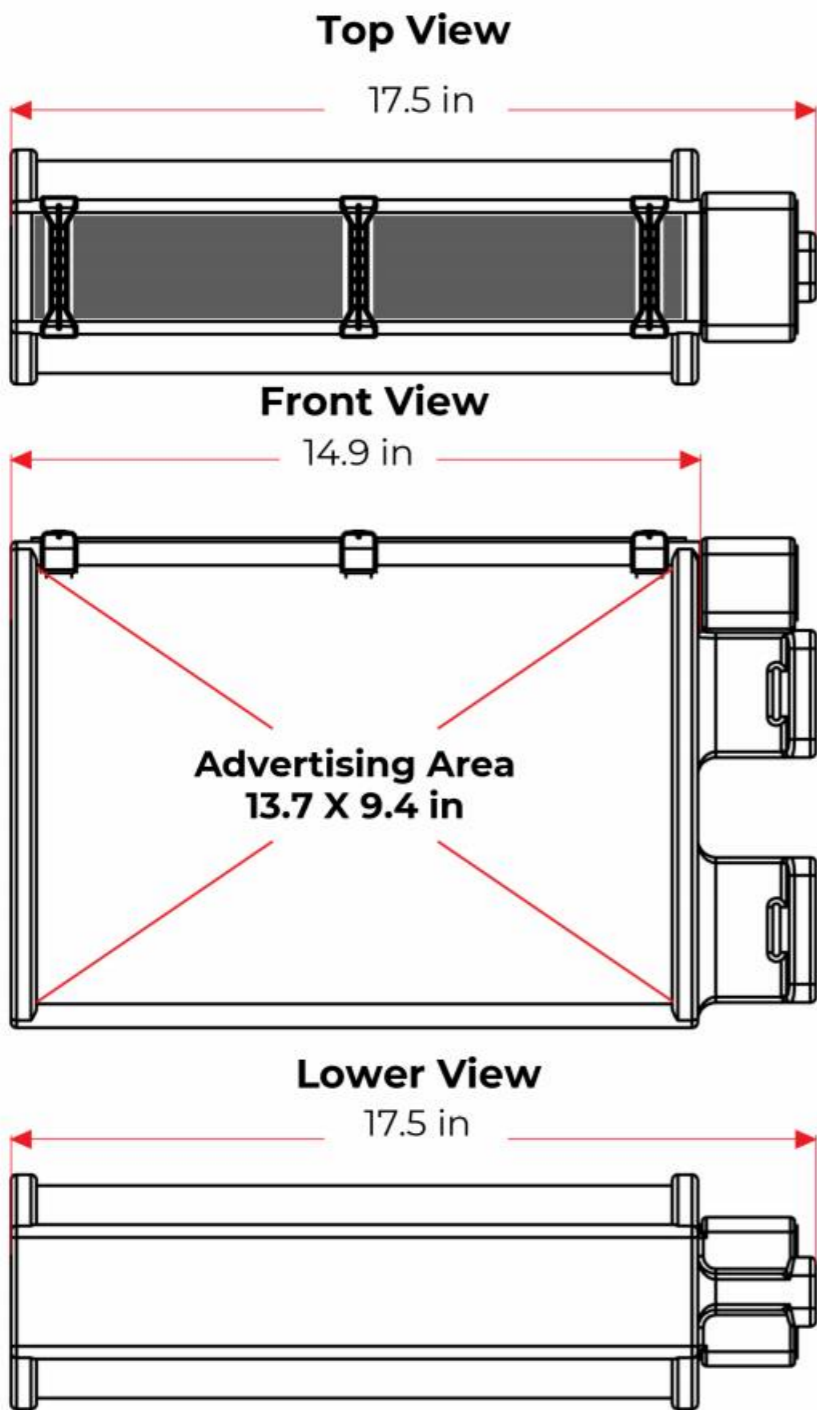

SOLAR 390

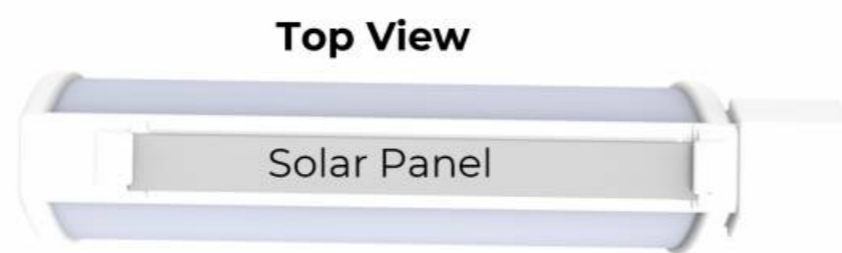

INSTALLATION

- Safety system with straps included:

The safety system is equipped with straps, providing a complete and reliable solution for your tranquility.



Pyramid Shaped



2 integrated joins

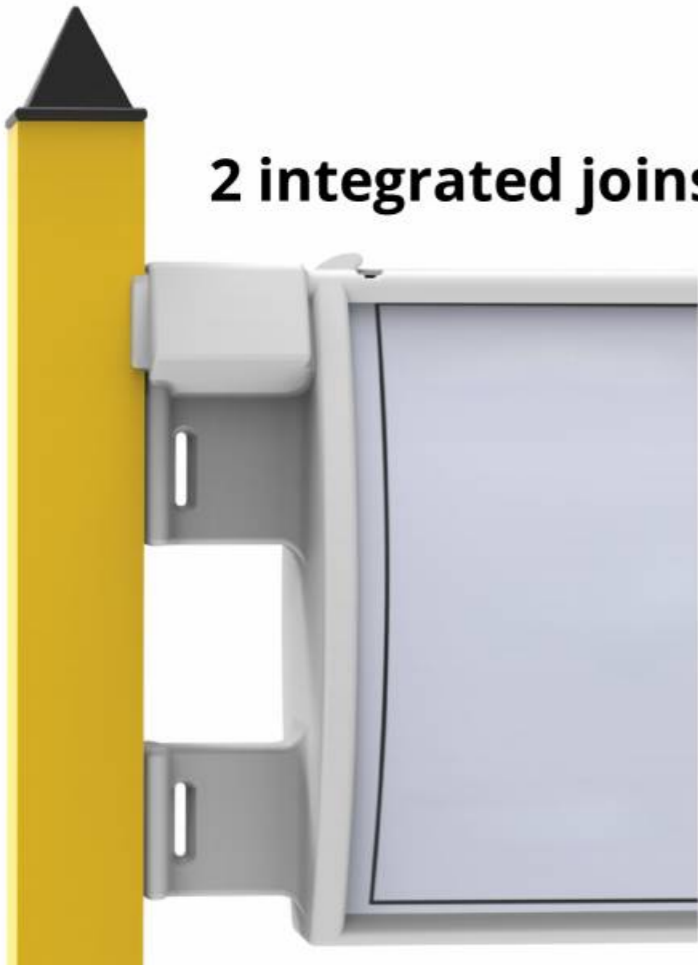

- With 2 integrated joins for their installation. A vandal-proof street sign, easy to install and can be used as advertisement.



Installation with straps





LABEL/SIGN EXAMPLES

NEW CITY 390

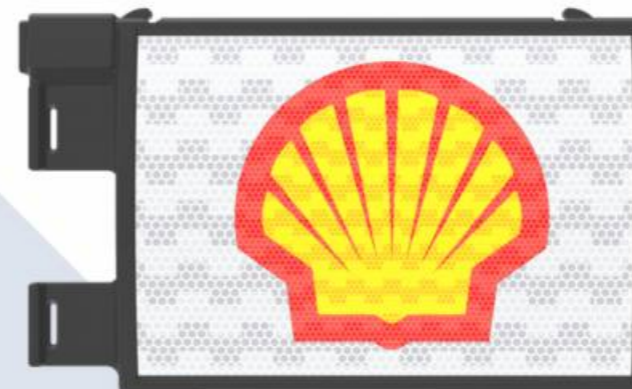
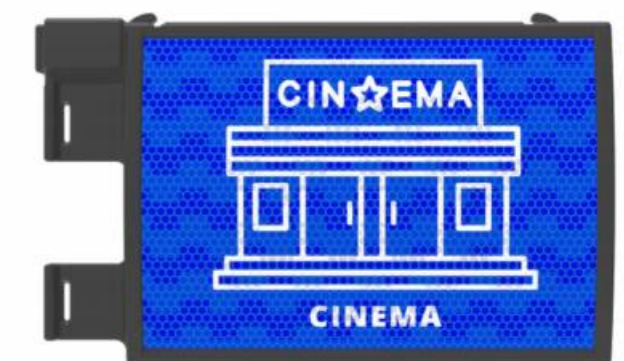

LABEL/SIGN EXAMPLES

STREET SIGNS

SOLAR 390

390 WITH LIGHT





CONTACT US

 **88-A lago Ayarza, Miguel Hidalgo, CDMX**

 **Phone Number +52 (55) 5399-8671**

 **Whatsapp +52 (55) 8811-2082**

 **<https://multisenal.com>**