

## SELF FILLING ABSORB 940

Code: ABS-940

### WHAT'S AN ABSORB?



Impact attenuator or crash cushion with cushioning system to improve the absorption of impacts, its modular system doesn't deviate neither produce a rebound effect on the vehicle, due it transfers the energy.

Filling with water is perfect to cushion slight impacts of less than 4409 lbs, and filling with sand is suitable to cushion greater front impacts of less than 9920 lbs.

It is suggested to place them on diversions, forks, junctions, et al.

### FEATURES

- In soft collisions recover its original shape; otherwise absorbs the effects of the impact.
- **Comply with standard NOM-008-SCT2-2013.**
- Its function is based on three assembly types:
  1. Impact Attenuator (crash cushion): for streets with low traffic flow.
  2. Impact Attenuator (Crash cushion) + module 1: for sections with greater vehicle load.
  3. Impact Attenuator (Crash cushion) + module 1 + universal module: for a better impact coverage can get to 6 modules, depending on the road risks.
- Self-filling device with rain water thanks to its upper cap.
- Lower cap for its draining.
- Solid structure manufactured in one piece; available in yellow, blue or green.
- Environment resistant and UV protection.
- This device transfer the energy.
- With 2 engineer prismatic reflective for better visibility at night or low light conditions.
- Flashing light powered by solar energy.
- 1 day of charge under sun exposure provides 36 hours of operation (flashing mode).
- Automatic light; turns ON in dark and turns OFF with light.
- Battery works during 36 hours after a complete charge.



# SELF FILLING ABSORB 940

Code: ABS-940

**Main module**  
Capacity 248-gal.

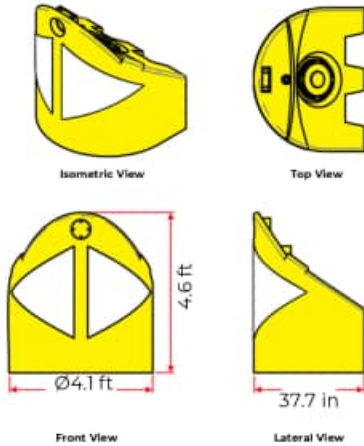

**Coupling module**  
Capacity 203-gal.

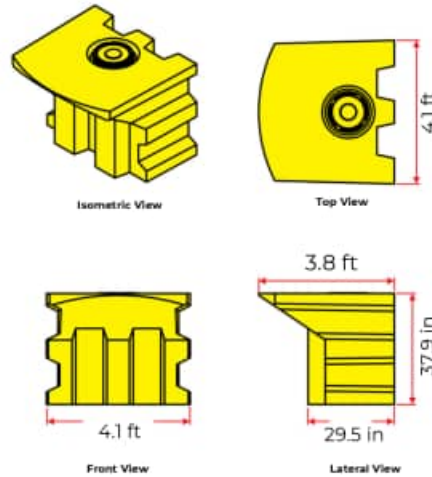

**Universal module**  
Capacity 176-gal.

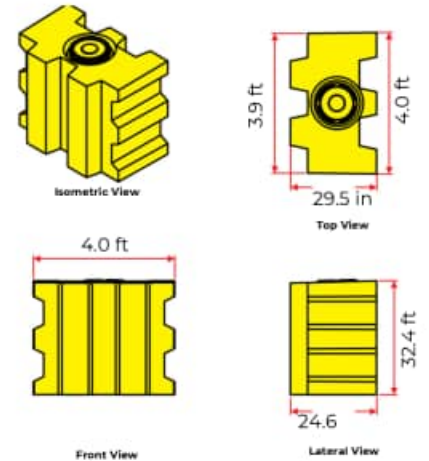

## MEASUREMENTS

Dimensions and other measures are nominal and may vary by +/- 2%.

**Impact Attenuator (Crash Cushion)**

- Length: 37.7 in
- Width: 4.1 ft
- Height: 4.6 ft

**Module 1**

- Length: 3.8 ft
- Width: 4.1 ft
- Height: 37.9 in

**Universal Module**

- Length: 3.8 ft
- Width: 4.1 ft
- Height: 37.9 in

**Reflective Sheeting Color**

- White

**Impact Attenuator Weight: empty**

- 77.161 lbs.

**Module 1 Weight: empty**

- 110.231 lbs.

**Universal Module Weight: empty**

- 77.161 lbs.

**Impact Attenuator Filling Capacity**

- 248-gal

**Module 1 Filling Capacity**

- 203-gal

**Universal Module Filling Capacity**

- 176-gal

# SELF FILLING ABSORB 940

Code: ABS-940

**Waterfilled  
TL (Test Level)**

