

## SOLAR NESTABLE BARRIER 850

Code: BA-AN-850S

### GREAT SAVINGS IN TRANSPORT & STORAGE !



### UNITY IS STRENGTH

This solar barrier is an efficient and versatile tool to guarantee road safety, specially in areas without public lighting.

Designed to delineate and sign, ideal to guide motorists, manage traffic and prevent accidents, providing a reliable protection to users.

Perfect to block access, sign works, separate lanes, deviate routes or delineate sport activities and special events, its innovative design allow a fast set and removal of the barrier.

Besides, nestable structure optimize storage and transport, combining practicality, safety and economy in a single device.

### FEATURES

- Modular barrier of easy installation, standing out as an exclusive option on market.
- Design saves up to 75% in storage and transportation costs, transforming into an economic alternative for different signage needs.
- Adjustable to different lengths, adapting to the specific requirements of each project or event.
- Manufactured in high density polyethylene, with UV protection, guaranteeing a long life span, resistance to inclemency and tolerance to temperature changes.
- Two engraved chevrons in each side, it can equip with reflective material (optional) for greater visibility.
- Fast and easy installation with male-female system, allowing one person can set it with a minimum effort.
- Designed to guide people to safe zones efficiently.
- These features make of nestable road barriers an efficient and convenient option for traffic control and management.

#### SOLAR SYSTEM

- Lighted by ultrabright latest generation LEDs.
- Option to have one or two solar cells, with an excellent light diffusion.
- Batteries to recharge during 5 hours with a durability of 12 hours working.
- JVM circuit for the correct functioning, synchronizable among all the barriers.



Engraved chevrons in body of barrier



Handle to manage



Safe coupling



Solar cell

# SOLAR NESTABLE BARRIER 850

Code: BA-AN-850

## MEASUREMENTS

Dimensions and other measures are nominal and may vary by + - 2%.

**Total**

- Total Length: 59.0 in
- Width: 17.7 in
- Height: 33.4 in

**Color of reflector**

- White

**Weight**

- 22,046 or 35,273 lbs depending the cost

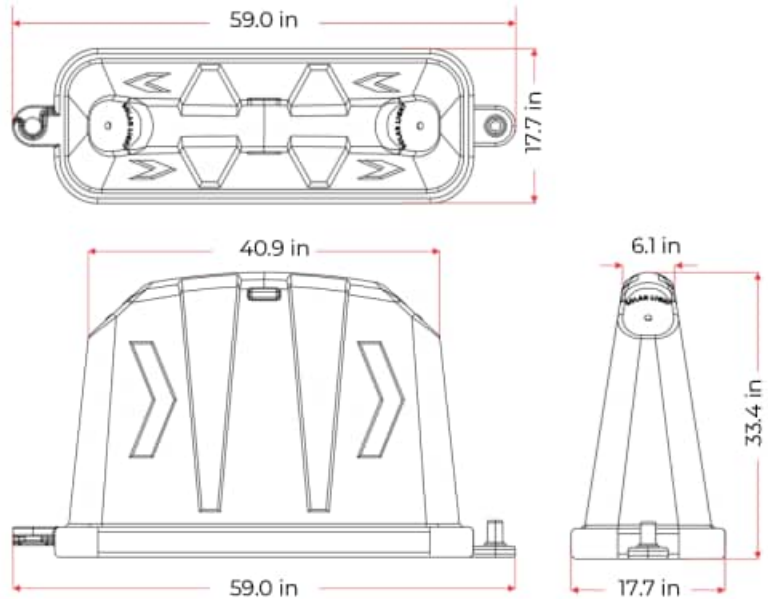

Dry box of 53" with approx. 1,134 nestable barriers.  
Channelizing 5,580 linear ft.