

TRAFISIT 109

Traffic Drum with Reflective sheeting

Código: TSL-109



WHAT'S A TRAFFIC DRUM?

Traffic Drums are safety devices in cylindrical shape manufactured in high density polyethylene, used to delimit work areas and can integrate reflective sheeting if desired or required.

These devices help to reduce speed according to the circulation on a closed space, such as parking lots, where both, motorists and pedestrians coexist day to day.

Ideal to divert and close ample highways with 3 or more lanes, occupying more space, thus are more visible to a longer distance. These are generally used in road traffic due to their high visibility at day and night, thanks to their color and size that distinguish from the rest of the view.

These items are very easy to install.

FEATURES

- Traffic Drums are very important for a correct traffic flow, avoiding any accident thanks to this signaling type. These devices will let us know about pedestrian crossings, diversions, collapse, et al.
- The perfect, clear and conspicuous tool to warn motorists and pedestrians about near risks of danger, these can be a dump or workers performing maintenance tasks.
- Very useful for work protection in highways.
- Out top quality guarantee a long lifespan thanks to its resistance to inclemency and UV-rays.
- Easy to clean, resists liquids and solvents.
- Option to have a removable counterweight base with handle, providing more stability and avoid tipping caused by wind.
- Top handle that allows their mobility, they also have boreholes to install a warning lamp.
- 100 % stackable.



TRAFISIT 109

Traffic Drum with Reflective sheeting

Code: TSL-109

MEASUREMENTS

Dimensions, and other measures are nominal and may vary by +/- 2%.

Manufactured in • High density polyethylene

Measurements

- Upper diameter: 17.5 in
- Lower diameter: 19.8 in
- Height: 3.5 ft

Measurements with base

- Upper diameter: 17.5 in
- Lower diameter: 23.0 in
- Height: 3.75 ft

Tensile Strength in yield point (ASTM D 638) • 17.3 mpa

Tensile strength in breaking point (ASTM D638) • 27.2 mpa

Yield point elongation (ASTM D 638) • 17.4 %

Elongation at break (ASTM D 638) • 1500 %

Flexural modulus (ASTM D 638) • 610 mpa

Impact strength Izod (ASTM D 256) • 530 j/m

Tensile impact strength (ASTM D 1822) • 163 kj/m²

Impacto arm 40°C, 3.2 mm • 23 900 j/m

Softening point (vicat) (ASTM D 1525) • 113°C or 235.4 °F

Heat deflection temperature (ASTM D 648) • 80°C or 176 °F

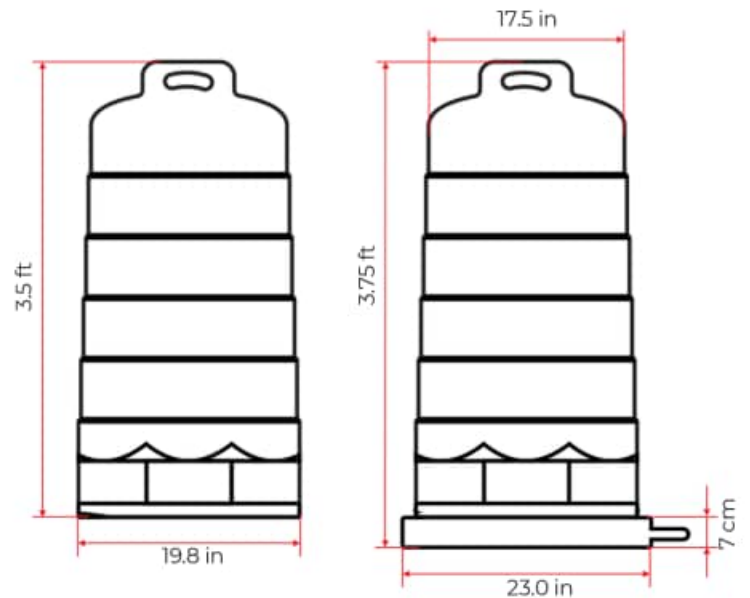

OPTIONAL REFLECTIVE SHEETING

• Engineer grade

Brightness (reflectometer 85°) • Over 40°

Stress testing (300 mm/min.) • Approximately 2.25 kgf

Heat resistance (71 + - 3°C x 24 hrs.) (159.8 + - 99.3 °F x 24 hrs.) • It doesn't affects

Cold resistance (-57 + - 3°C x 7 hrs.) (-70.6 + - 37.4°F x 7 hrs.) • It doesn't affects

